



Z185-FS-45

6 [152] DIAMETER CORNICE DRAIN W/ FLAT STRAINER AND 45° OUTLET

SPECIFICATION SHEET

TAG _____

Dimensional Data (inches and [mm]) are Subject to Manufacturing Tolerances and Change Without Notice

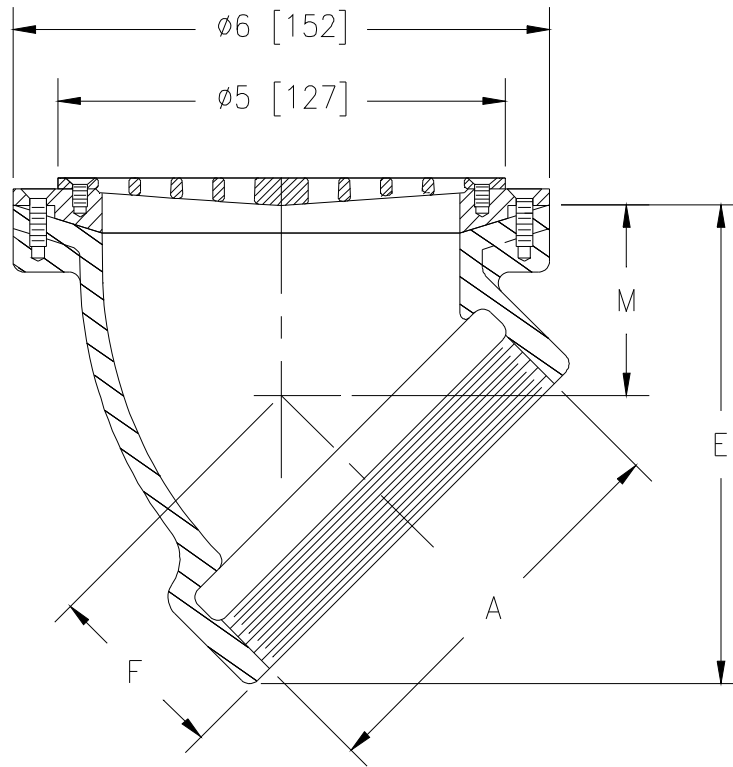

Dimensions In Inches [mm]			Approx. Wt. Lbs.[kg]	Grate Open Area Sq. In.[cm ²]
A- Pipe Size	F	M		
3 [76]	3-1/2 [89]	3 [76]	9 [4]	8 [52]
4 [102]	2 [51]	2-1/4 [57]		

ENGINEERING SPECIFICATION: ZURN ZN185-FS-45 6" [152mm] Diameter cornice drain, Dura-Coated cast iron 45° outlet body, nickel bronze flat strainer and membrane flashing clamp.

OPTIONS (Check/specify appropriate options)

PIPE SIZE

3 [76]
4 [102]

(Specify size/type) **OUTLET**

_____ IP Threaded
_____ IP Threaded

'E' BODY HT. DIMENSION

5 [127]
5-3/8 [137]

PREFIXES

_____ ZN D.C.C.I. Body with Polished Nickel Bronze Strainer*

SUFFIXES

_____ -G Galvanized Cast Iron
_____ -VP Vandal Proof Secured Top

* Regularly furnished unless otherwise specified.