



Z556-FO
8 [203] ADJUSTABLE HEAVY-DUTY DRAIN
W/ 9-1/8 x 3-3/8 [232 x 86] FUNNEL

SPECIFICATION SHEET
TAG _____



Dimensional Data (inches and [mm]) are Subject to Manufacturing Tolerances and Change Without Notice

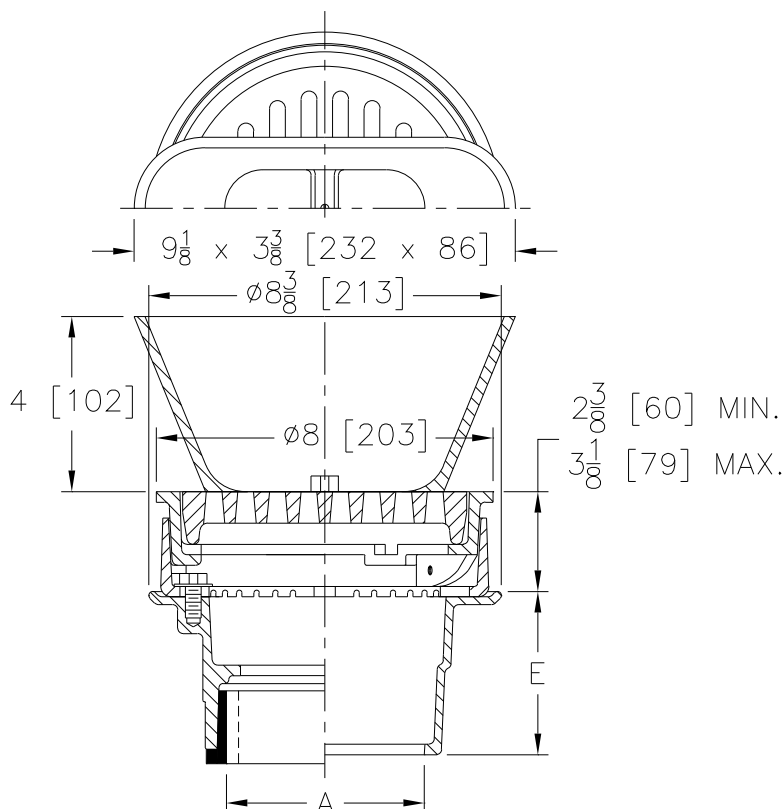

A Pipe Size Inches [mm]	Approx. Wt. Lbs. [kg]	Grate Open Area Sq. In. [cm ²]
2-3-4 [51-76-102]	22 [10]	11 [71]

ENGINEERING SPECIFICATION: ZURN Z556-FO
 8 [203] diameter heavy-duty floor drain, Dura-Coated cast iron bottom outlet body, seepage pan and combination membrane flashing clamp and frame, heavy-duty anti-tilt cast iron grate with 9-1/8 x 3-3/8 [232 x 86] funnel.

OPTIONS (Check/specify appropriate options)

PIPE SIZE

- 2,3,4 [51,76,102]
- 2,3,4 [51,76,102]
- 2,3,4 [51,76,102]
- 2,3,4 [51,76,102]
- 6 [152]
- 2,3,4 [51,76,102]

(Specify size/type) **OUTLET**

- _____ IC Inside Caulk
- _____ IG Inside Gasket
- _____ IP Threaded
- _____ NH No-Hub
- _____ NH No-Hub (w/ Z1040)
- _____ NL Neo-Loc

E BODY HT. DIM.

- 3-7/8 [98]
- 3-7/8 [98]
- 2-5/8 [67]
- 3-7/8 [98]
- 5-1/2 [140]
- 3-3/4 [95]

PREFIXES

- _____ Z D.C.C.I. Body with Grate*
- _____ ZN D.C.C.I. Body with Polished Nickel Bronze Top* (Add 3/16 [5] to Min./Max. Dimension)

SUFFIXES

- _____ -AR Acid-Resisting Epoxy Coated Cast Iron
- _____ -FS Floating Slab
- _____ -G Galvanized
- _____ -P 1/2 [13] Trap Primer Connection
- _____ -VP Vandal-Proof Secured Top
- _____ -X Squeezin Backwater Valve
- _____ -Y Sediment Bucket
- _____ -90 90° Threaded Side Outlet Body (IP or NH only)

*REGULARLY FURNISHED UNLESS OTHERWISE SPECIFIED

REV. -	DATE: 10/7/11	C.N. NO. 122242
DWG. NO. 303867 PRODUCT NO. Z556-FO		