



Z1280-N42

WOOD STUD SUPPORTED WATER CLOSET SUPPORT SYSTEM

SPECIFICATION SHEET

TAG _____

Dimensional Data (inches and [mm]) are Subject to Manufacturing Tolerances and Change Without Notice

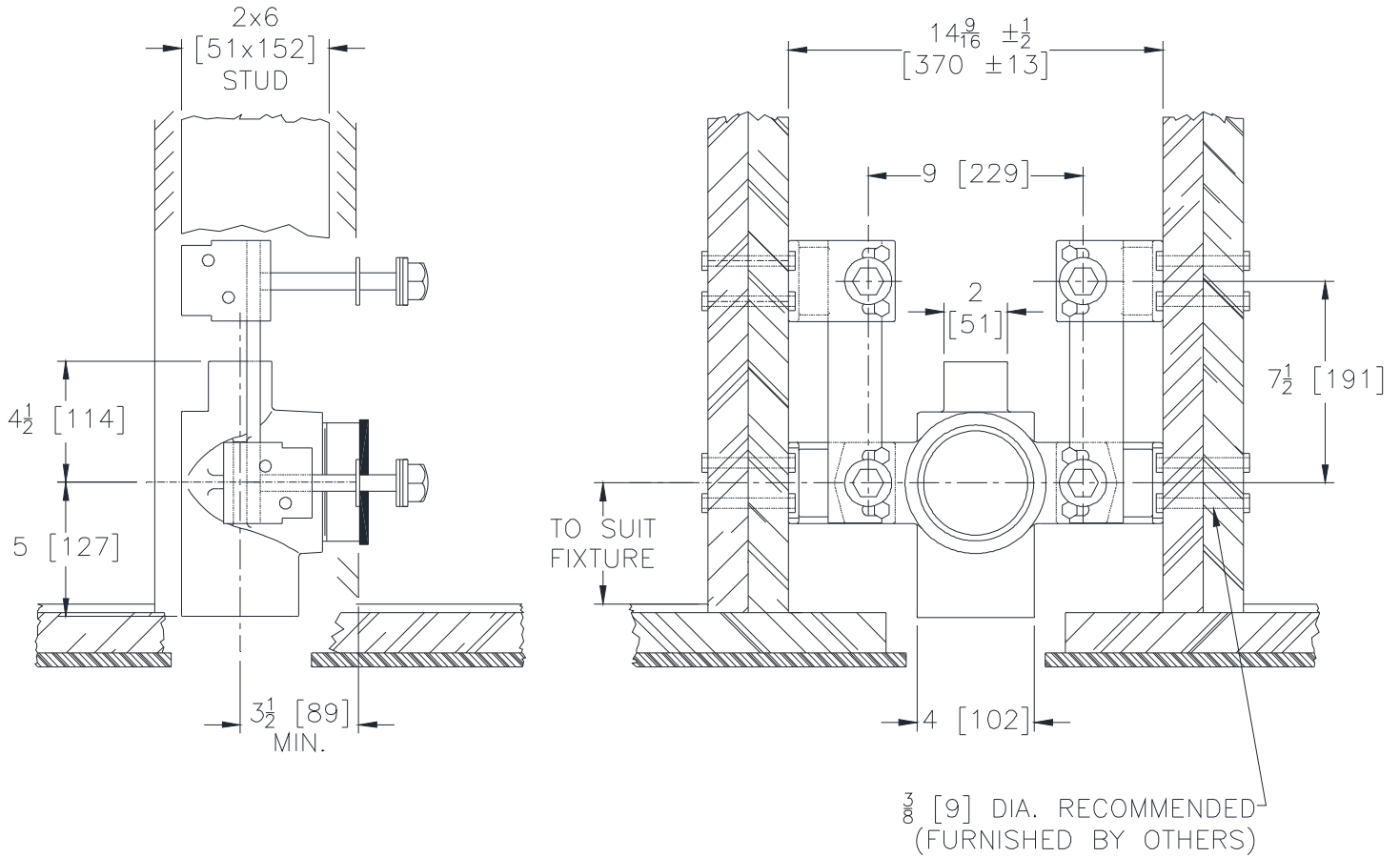

| Product No. | Approx. Wt. Lbs. [kg] |
|-------------|-----------------------|
| Z1280-N42 | 40 [18] |

ENGINEERING SPECIFICATION: ZURN Z1280-N42

Wood stud supported water closet support system. Complete with Dura-Coated cast iron 4" [102mm] no-hub fitting with 2" [51mm] vent, support brackets, corrosion resistant ABS coupling, fixture bolts and trim, and bonded "Neo-Seal" gasket.

PREFIXES

___ Z Dura-Coated Fitting and Bracket System*

SUFFIXES

___ -X4 4 [102] Inch High Foot Extension (For -Y only)

___ -Y Foot Support System

* Regularly furnished unless otherwise specified.

Zurn Industries, LLC | Specification Drainage Operation
 1801 Pittsburgh Avenue, Erie, PA U.S.A. 16502 · Ph. 855-663-9876, Fax 814-454-7929
 In Canada | Zurn Industries Limited
 3544 Nashua Drive, Mississauga, Ontario L4V 1L2 · Ph. 905-405-8272, Fax 905-405-1292
www.zurn.com

Rev. D
 Date: 10/18/17
 C.N. No. 138946
 Prod. | Dwg. No. Z1280-N42