



# Z352-76

SPECIFICATION SHEET

## 6 1/8 [156] DIAMETER MULTI-STAGE PLANTING AREA DRAIN W/ 15 [381] DIAMETER LOWER BODY

TAG \_\_\_\_\_

Dimensional Data (inches and [mm]) are Subject to Manufacturing Tolerances and Change Without Notice

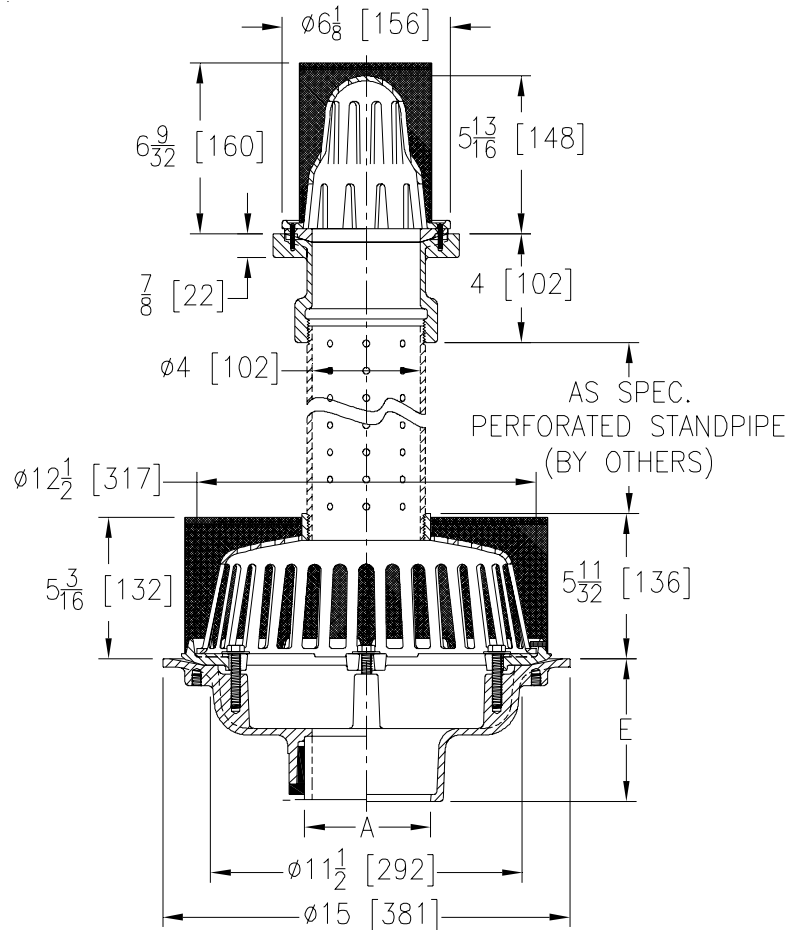

A Pipe Size In.	Approx. Wt. Lbs. [kg]	Dome Open Area Sq. In. [cm <sup>2</sup> ]	
		Upper	Lower
2-3-4 [51-76-102]	34 [15]	20 [126]	103 [665]
5-6 [125-150]	35 [16]		

### ENGINEERING SPECIFICATION: ZURN Z352-76

6 1/8 [156] Diameter Planting area drain, Dura-Coated cast iron body with threaded outlet and high plain bronze dome with stainless steel mesh screen. Lower body is a dura-coated cast iron 15 [381] diameter body with combination membrane flashing clamp/gravel guard with secured low silhouette cast iron dome, stainless steel mesh screen and 4 [102] dia. perforated standpipe with 3/8 [10] dia. holes (by others).

### OPTIONS (Check/specify appropriate options)

#### PIPE SIZE

2 thru 6 [51 thru 152,203]  
 2 thru 6 [51 thru 152,203]  
 2 thru 6 [51 thru 152,203]  
 2,3,4 [51,76,102]  
 6 [152]

#### (Specify size/type) OUTLET

\_\_\_ IC Inside Caulk  
 \_\_\_ IP Threaded  
 \_\_\_ NH No-Hub  
 \_\_\_ NL Neo-Loc  
 \_\_\_ NL Neo-Loc

#### E BODY HT. DIM.

5 1/4 [133]  
 3 3/4 [95]  
 5 1/4 [133]  
 4 9/16 [116]  
 5 7/16 [112]

#### PREFIXES

\_\_\_ ZRB D.C.C.I. Body with Bronze Dome and Stainless Steel Mesh Screen.\*

#### SUFFIXES

\_\_\_ -C Underdeck Clamp  
 \_\_\_ -R Roof Sump Receiver  
 \_\_\_ -VP Vandal-Proof Secured Top

REV. DATE: 3/20/08 C.N. NO. 98262

DWG. NO. P-15531 PRODUCT NO. Z352-76

\*REGULARLY FURNISHED UNLESS OTHERWISE SPECIFIED

ZURN INDUSTRIES, LLC ♦ SPECIFICATION DRAINAGE OPERATION ♦ 1801 Pittsburgh Ave. ♦ Erie, PA 16514

Phone: 814/455-0921 ♦ Fax: 814/454-7929 ♦ World Wide Web: www.zurn.com

In Canada: ZURN INDUSTRIES LIMITED ♦ 3544 Nashua Drive ♦ Mississauga, Ontario L4V1L2 ♦ Phone: 905/405-8272 Fax: 905/405-1292