



Z100-289

15 [381] DIAMETER MAIN ROOF DRAIN WITH ADJUSTABLE EXTENSION AND STABILIZER ASSEMBLY

SPECIFICATION SHEET

TAG _____

Dimensional Data (inches and [mm]) are Subject to Manufacturing Tolerances and Change Without Notice

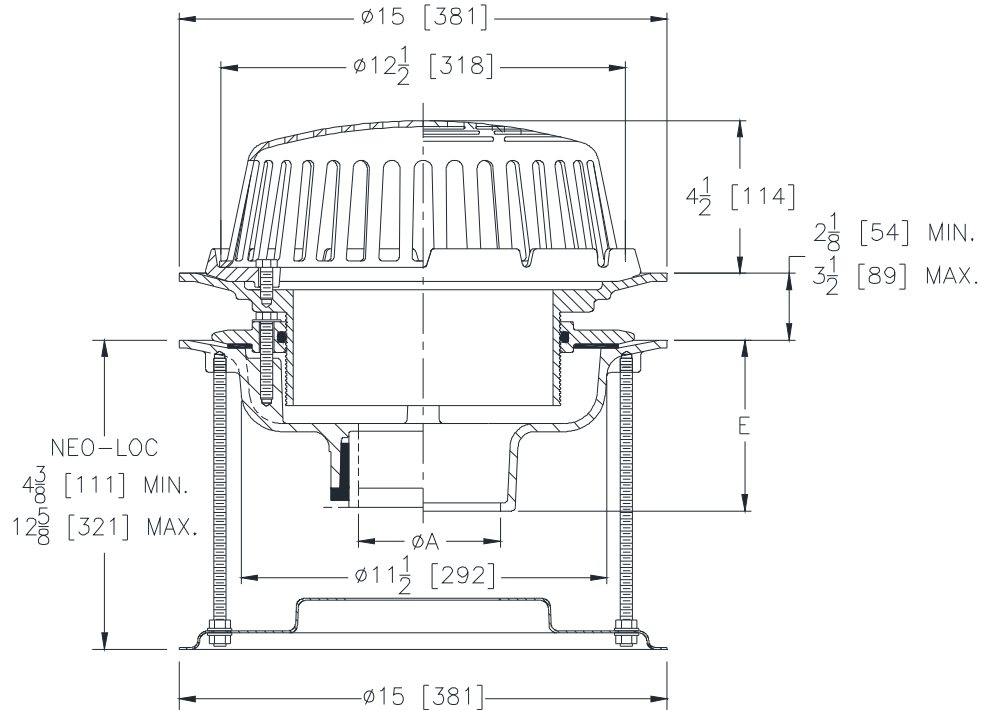

A- Pipe Size In.	Approx. Wt. Lbs. [kg]	Dome Open Area Sq. In. [cm ²]
2-3-4 [51-76-102]	38 [17]	103 [665]

ENGINEERING SPECIFICATION: ZURN Z100-289

15 [381] Diameter roof drain. Dura-Coated cast iron body with combination membrane flashing clamp/gravel guard, adjustable extension, secondary clamping collar with o-ring, low silhouette Poly-Dome strainer, and stabilizer assembly

OPTIONS (Check/specify appropriate options)

PIPE SIZE

(Specify size/type) **OUTLET**

E BODY HT. DIM.

2-3-4 [51-76-102]
2-3-4 [51-76-102]

_____ NH No-Hub
_____ NL Neo-Loc

5-1/4 [133]
4-5/8 [117]

PREFIXES

_____ Z D.C.C.I. Body with Poly-Dome*
_____ ZA D.C.C.I. Body with 6-3/4 [171] High Aluminum Dome
_____ ZC D.C.C.I. Body with Cast Iron Dome
_____ ZRB D.C.C.I. Body with Plain Bronze Dome

SUFFIXES

_____ -AR Acid Resistant Epoxy Coated Finish	_____ -SC Secondary Clamping Collar
_____ -AW 3/4 [19] to 4 [102] Adj. Water Level Regulator	_____ -SS Stainless Steel Mesh Screen Over Dome
_____ -BS Bronze Mesh Screen Over Dome	_____ -ST Dome with Solid Top (ZA, ZC, & ZRB Only)
_____ -DX Dex-o-tex Flange	_____ -TC Neo-Loc Test Cap Gasket (2-4 [51-102] NL Bottom Outlet Only)
_____ -E Static Extension 1 [25] thru 4 [102] (Specify Ht.)	_____ -VP Vandal-Proof Secured Top
_____ -FG Flush Grate	_____ -W2 2 [51] Internal Water Dam
_____ -G Galvanized Cast Iron	_____ -W3 3 [76] Internal Water Dam
_____ -GD Galvanized Cast Iron Dome (ZC only)	_____ -W4 4 [102] Internal Water Dam
_____ -HD 6-3/4 [171] High Aluminum Dome Strainer (148 Sq. In. [955 cm ²] Open Area)	_____ -84 Stainless Steel Perforated Gravel Guard
_____ -R Roof Sump Receiver	_____ -85 Stainless Steel Perforated Extension
	_____ -89 2 [51] High External Water Dam

* Regularly furnished unless otherwise specified.

Zurn Industries, LLC | Specification Drainage Operation
1801 Pittsburgh Avenue, Erie, PA U.S.A. 16502 · Ph. 855-663-9876, Fax 814-454-7929
In Canada | Zurn Industries Limited
3544 Nashua Drive, Mississauga, Ontario L4V 1L2 · Ph. 905-405-8272, Fax 905-405-1292
www.zurn.com

Rev. -
Date: 06/26/14
C.N. No. 131149
Prod. | Dwg. No. Z100-289