



ZA880-300A-86

SPECIFICATION SHEET

3 [76] WIDE REVEAL CUSTOM TRENCH DRAIN SYSTEM WITH-DOG GRATE

TAG _____

Dimensional Data (inches and [mm]) are Subject to Manufacturing Tolerances and Change Without Notice

SPECIFYING ENGINEER IS RESPONSIBLE FOR CONCRETE ENCASEMENT AND REINFORCING BASED UPON APPLICATION AND LOCAL CODES

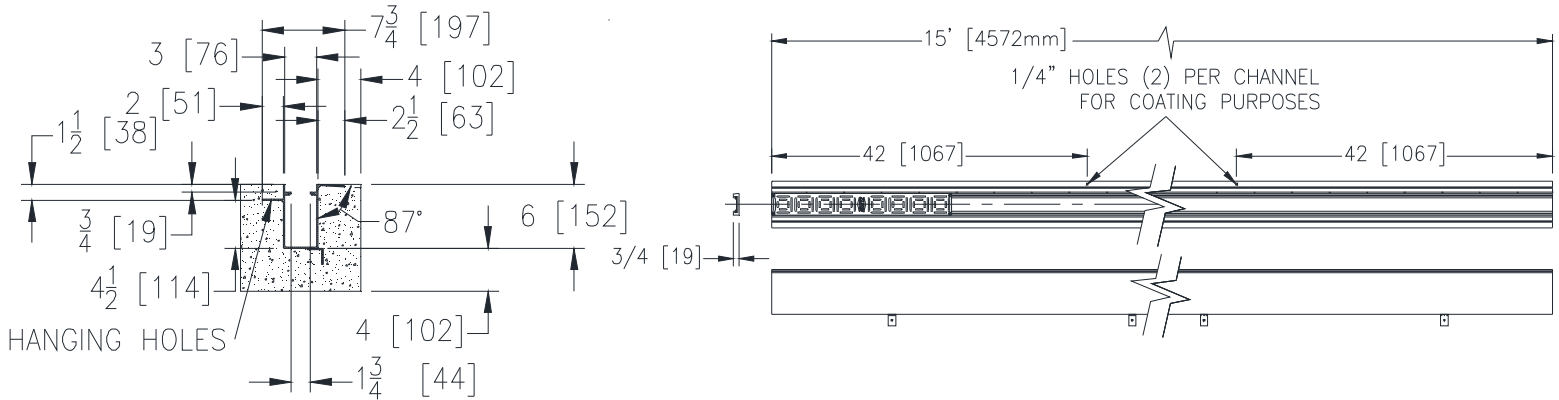

ENGINEERING SPECIFICATION: Zurn ZA880-300A-86

Custom Channels are 15' [4572mm] long, 3-1/4" [82mm] wide reveal, 3" [76mm] throat, and have a 5-7/8" [149mm] invert. Modular channel sections made of 0% water absorbent Aluminum Alloy T-6063T5. Channel connections to be field welded. Channels weigh less than 2 lbs. [.91kg] per linear foot, have a Manning's coefficient of .002 and neutral 0% built in slope. Channels have 2" [51mm] flange on one side to mechanically lock into the concrete surround. Channels provided with weep holes above the anchoring flange. 2-1/2" [63mm] flange to be located on the opposite side flush with the top of channel. Trench shall be clear coated to 2" [51mm] of ends to allow for field welding. Securing tabs will be located on bottom of the channel below the flush flange every 32" [813mm]. Channel is produced in the U.S.A..

DOG GRATE ENGINEERING SPECIFICATION: Zurn 2.9" [74mm] Wide Heel-Proof Ductile Iron Grate. Ductile grate conforms to ASTM A536 grade 80-55-06. Iron conforms to ASTM A48 Class 25. Supplied in 24" [610mm] nominal lengths, with mechanical lockdown. Open area is 9.43 sq. in/ft [1854 sq. mm/m].

SYSTEM SPECIFICATION: Zurn has produced this custom design based off of the specification provided. This system is designed based off a 3" [76mm]/hr rainfall rate. Load carrying capabilities have not been tested and will vary based on installation methods. Specifying Engineer is responsible for approval of design and application integrity.

PREFIX OPTIONS (Check/specify appropriate options)

___ Z Fifteen-foot, Extruded Aluminum *

SUFFIX OPTIONS (Check/specify appropriate options)

Outlet Adapters Add/Each

- ___ -E1 Closed End Cap
- ___ -U1.5 1-1/2 [38] No-Hub Bottom Outlet
- ___ -U2 2 [51] No-Hub Bottom Outlet

Miscellaneous Options

- ___ -KC Clamp Collar and Pan (includes-K)



* Regularly furnished unless otherwise specified.