



# Z535-76

16-3/4 [425] SQ. HEAVY-DUTY PARKING  
STRUCTURE DRAIN W/ 1 [25] EXTENSION

SPECIFICATION SHEET

TAG \_\_\_\_\_

Dimensional Data (inches and [ mm ]) are Subject to Manufacturing Tolerances and Change Without Notice

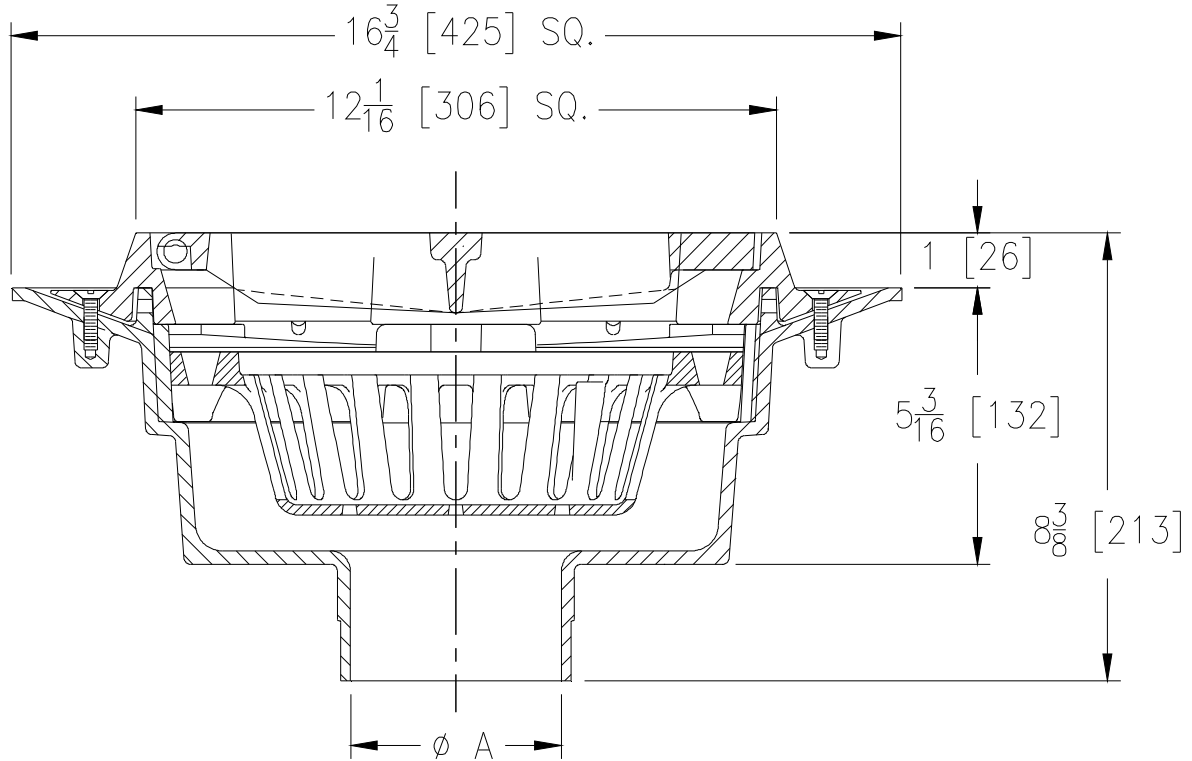

A Pipe Size Inches [mm]	Approx. Wt. Lbs. [kg]	Grate Open Area Sq. In. [sq. cm]
3,4,6,8 [76,102,152,203]	29 [13]	57 [368]

### Engineering Specification: ZURN Z535-76

12" [305mm] square top heavy-duty parking structure drain. Oven cured epoxy-coated iron body with bottom outlet, with 1" [25mm] extension clamping frame, membrane, anti-ponding slots, sediment bucket and heavy-duty anti-tilt hinged slotted grate, stainless steel hinge pins.

### Options (Check/specify appropriate options)

#### Pipe Size (ØA)

3,4,6,8 [76,102,152,203]

#### (Specify size) OUTLET

\_\_\_\_\_ NH      No-Hub

#### Prefixes

\_\_\_\_\_ Z      A.R.C. Iron Body and Top\*  
\_\_\_\_\_ ZA      A.R.C. Aluminum Body and Top

#### Suffixes

\_\_\_\_\_ -CI      Cast Iron Grate (For ZA option only)  
\_\_\_\_\_ -L      Locking Device

\* Regularly furnished unless otherwise specified.