



Z1717-78

SCUPPER DRAIN W/ STAINLESS STEEL GRATE

SPECIFICATION SHEET

TAG _____

Dimensional Data (inches and [mm]) are Subject to Manufacturing Tolerances and Change Without Notice

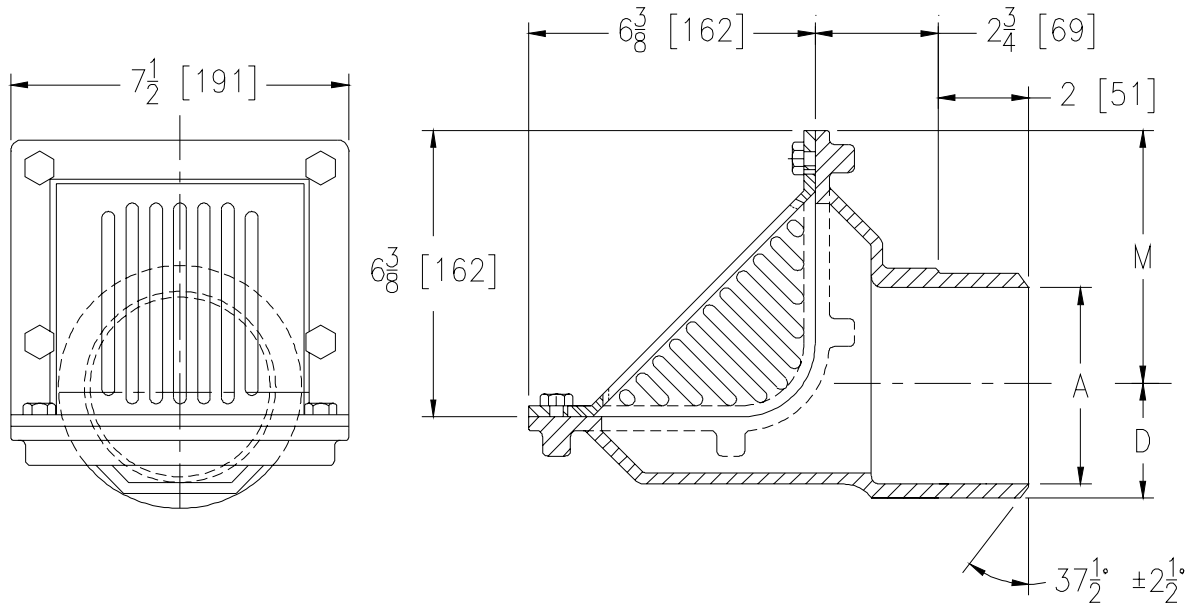

Dimensions in Inches			Approx. Wt. Lbs. [kg]	Grate Open Area Sq. In. [cm ²]
A- Pipe Size	D	M		
3 [76]	2 [51]	6 1/8 [156]	24 [11]	20 [129]
4 [102]	2 1/2 [63]	5 5/8 [143]		

ENGINEERING SPECIFICATION: ZURN Z1717-78
Scupper drain with Type 304 (CF8) stainless steel body, oblique grate and clamp collar.

OPTIONS (Check/specify appropriate options)

PIPE SIZE

3-4 [76-102]

(Specify size) **OUTLET**

_____ BW Butt-weld (Specify Schedule 10,40 or 80)

PREFIXES

_____ Z Type 304 (CF8) Stainless Steel Body and Top*

OPTIONS

_____ -VP Vandal-Proof Secured Top

REV.	DATE: 5/13/09	C.N. NO. 99980
DWG. NO. P-15712 PRODUCT NO. Z1717-78		

*REGULARLY FURNISHED UNLESS OTHERWISE SPECIFIED