



Z100-167

15 [381] DIA. ROOF DRAIN W/ INTERNAL CONTROLLED FLOW STANDPIPE AND PERFORATED DOME

SPECIFICATION SHEET

TAG _____

Dimensional Data (inches and [mm]) are Subject to Manufacturing Tolerances and Change Without Notice

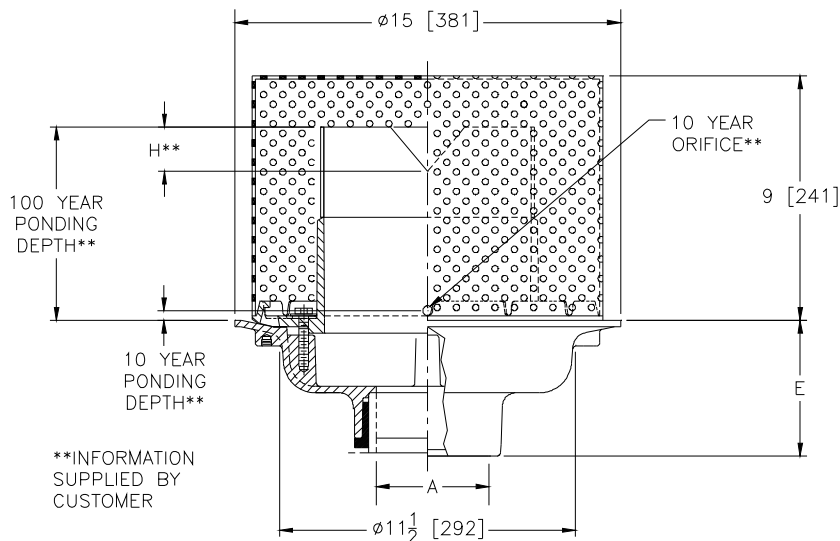

A- Pipe Size In.	Approx. Wt. Lbs. [kg]	Dome Open Area Sq. In. [cm ²]
2-3-4 [51-76-102]	26 [12]	88 [568]
5-6 [127-152]	27 [12]	
8 [203]	28 [13]	

ENGINEERING SPECIFICATION: ZURN Z100-167 15" [381] Diameter roof drain. Dura-Coated cast iron body with combination membrane flashing clamp/gravel guard, internal controlled flow standpipe and perforated metal dome.

OPTIONS (Check/specify appropriate options)

PIPE SIZE

- 2 thru 6, 8 [51 thru 152, 203]
- 2 thru 6, 8 [51 thru 152, 203]
- 2 thru 6, 8 [51 thru 152, 203]
- 2,3,4 [51, 76, 102]

(Specify size/type) **OUTLET**

- _____ IC Inside Caulk
- _____ IP Threaded
- _____ NH No-Hub
- _____ NL Neo-Loc

E BODY HT. DIM.

- 5 1/4 [133]
- 3 3/4 [95]
- 5 1/4 [133]
- 4 5/8 [117]

PREFIXES

- _____ Z D.C.C.I. Body with perforated metal dome*

SUFFIXES

- _____ -AC Angular Underdeck Clamp
- _____ -AR Acid Resistant Epoxy Coated Finish
- _____ -C Underdeck Clamp
- _____ -DP Top-Set[®] Deck Plate
- _____ -DR Top-Set[®] Drain Riser
- _____ -DX Dex-o-tex Flange
- _____ -E Static Extension 1 [25] thru 4 [102] (Specify Ht.)
- _____ -EA Adjustable Extension Assembly 1 3/4 [44] thru 3 1/2 [89]
- _____ -ES Static Extension With Secondary Clamp
- _____ -G Galvanized Cast Iron
- _____ -R Roof Sump Receiver
- _____ -SC Secondary Clamping Collar
- _____ -TC Neo-Loc Test Cap Gasket (2"-4" NL Bottom Outlet Only)
- _____ -VP Vandal Proof Secured Top
- _____ -XJ Vertical Expansion Joint (See Z190)

- _____ -85 Stainless Steel Perforated Extension
- _____ -90 90° Threaded Side Outlet Body

*REGULARLY FURNISHED UNLESS OTHERWISE SPECIFIED

REV.	DATE: 8/27/04	C.N. NO. 92505
DWG. NO. P-15077		PRODUCT NO. Z100-167