



Z886-HD-LD-SW

6-3/4 [171] WIDE REVEAL TRENCH DRAIN SYSTEM W/ HEAVY-DUTY FRAME TAG _____
 ASSEMBLY W/ LIGHT-DUTY GRATES & 9 [229] SIDEWALL EXTENSION

Dimensional Data (inches and [mm]) are Subject to Manufacturing Tolerances and Change Without Notice

SPECIFYING ENGINEER IS RESPONSIBLE FOR CONCRETE ENCASEMENT AND REINFORCING BASED UPON APPLICATION AND LOCAL CODES

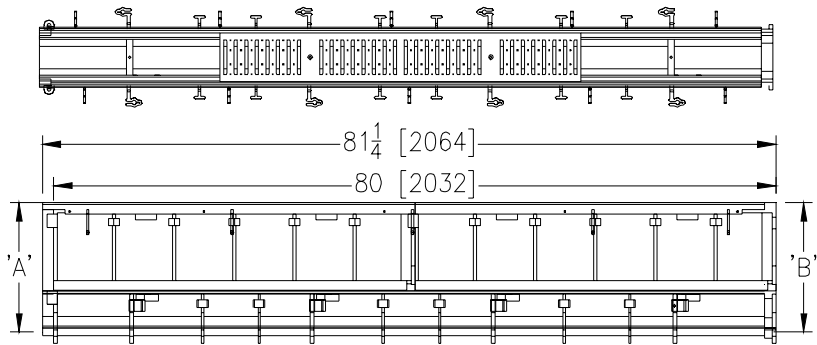
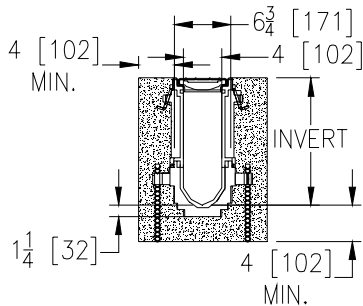

NOTE: + Actual Channel length is 81 1/4 [2064] to allow for overlap.

ENGINEERING SPECIFICATION: Zurn Z886-HD-LD-SW

Channels shall be 80 [2032] long, 6-3/4 [171] wide reveal and have a 4 [102] throat. Modular channel sections shall be made of 0% water absorbent High Density Polyethylene (HDPE). Shall have a positive mechanical connection between channel sections that will not separate during the installation and shall mechanically lock into the concrete surround every 10 [254]. Channels shall weigh less than 2.31 lbs.[1.05kg] per linear foot, have a smooth, 1-1/2 [38] radiused self cleaning bottom with a Manning's coefficient of .009 and .75% or neutral 0% built in slope. Channels shall have rebar clips standard to secure trench in its final location. Channels shall have HDPE SW Side Walls attached for an additional 9 [229] added to the standard channel invert for additional flow capability shown in chart below. Shall be provided with standard RFG grates that lock down to frame. Zurn 6 [152] wide reveal Reinforced Galvanized Steel Slotted Grate reinforcing conforming to ASTM specification A536-84, Grade 80-55-06. Fabricated Steel grate is rated class B per the DIN EN1433 top load classifications. Supplied in 40 [1016] nominal lengths with 3/8 [10] wide slots, and 3/4 [19] bearing depth. Grate has an open area of 13.68 sq. in per ft. [28,956 sq. mm per meter]. The .105 [2.66] thick Heavy-Duty Carbon Steel Frame Assembly conforms to ASTM specification A36 with 10 - 4 [102] long concrete anchors per 80 [2032]. Grate lockdown bars are to be integral to the frame The frame is supplied with a powder coated finish. All welds must be performed by a certified welder per ASTM standard AWS D1.1. Frames Shall be produced in the U.S.A. The System loading is based upon the grate being used.

PREFIX OPTIONS (Check/specify appropriate options)

- Z Six-foot, Eight-inch High Density Polyethylene (HDPE)*

SUFFIX OPTIONS (Check/specify appropriate options)

Outlet Adapters Add/Each

- E1 Closed End Cap
- E2 2 [51] No-Hub End Outlet
- E3 3 [76] No-Hub End Outlet
- E4 4 [102] No-Hub End Outlet
- E6 6 [152] No-Hub End Outlet
- U2 2 [51] No-Hub Bottom Outlet
- U3 3 [76] No-Hub Bottom Outlet
- U4 4 [102] No-Hub Bottom Outlet
- U6 6 [152] No-Hub Bottom Outlet

Frame Options

- CBF Black Acid Resistant Coated Top Frame

Grate Options (Load Classifications are per DIN EN1433)

- HPP Heel-Proof Polyethylene Grate - Class A
- RFG Reinforced Galvanized Steel Slotted Grate - Class B *
- RFS Reinforced Stainless Steel Slotted Grate - Class B
- RPG Reinforced Galvanized Perforated Grate - Class B
- RPS Reinforced Stainless Steel Perforated Grate - Class B

Miscellaneous Options

- VP Vandal-Proof Lockdown
- JC Joint Connector

MADE in the U.S.A. (Load Classifications are per DIN EN1433)

- AWG Aluminum Wire Grate - Class A
- FG Fabricated Galvanized Steel Slotted Grate - Class A
- FS Fabricated Stainless Steel Slotted Grate - Class A
- GG Fiberglass Grate - Class A
- PG Perforated Galvanized Steel Grate - Class A
- PS Perforated Stainless Steel Grate - Class A
- SBG-L Stainless Steel Bar Grate - Class B

Miscellaneous Options

- DB Bottom Dome Strainer

Decorative MADE in the U.S.A. (Load Classifications are per DIN EN1433)

- BZ Bronze Decorative Grate - Class A
- NBZ Nickel Bronze Decorative Grate - Class A
- PSR Perforated Stainless Steel Raised Grate - Class A
- SWG Stainless Steel Wire Grate - Class A

Trench No.	Flow		Flow		
	'A' Shallow Inv.	'B' Deep Inv.	(cfs)	(gpm)	(lps)
8601SW	12.50 [318]	13.10 [333]	1.25	563	35
8602SW	13.10 [104]	13.70 [348]	1.32	595	38
8603SW	13.70 [119]	14.30 [135]	1.40	627	40
8603NSW	14.30 [135]	14.30 [135]	-	-	-
8604SW	14.30 [235]	14.90 [150]	1.47	659	42
8605SW	14.90 [150]	15.50 [165]	1.54	691	44
8606SW	15.50 [165]	16.10 [180]	1.61	723	46
8606NSW	16.10 [180]	16.10 [180]	-	-	-
8607SW	16.10 [180]	16.70 [196]	1.68	755	48
8608SW	16.70 [196]	17.30 [211]	1.75	788	50
8609SW	17.30 [211]	17.90 [226]	1.83	820	52
8610SW	17.90 [226]	18.50 [241]	1.90	852	54
8611SW	18.50 [241]	19.10 [257]	1.97	884	56
8612SW	19.10 [257]	19.70 [272]	2.04	916	58
8612NSW	19.70 [272]	19.70 [272]	-	-	-
8613SW	19.70 [272]	20.30 [287]	2.11	949	60
8614SW	20.30 [287]	20.90 [302]	2.19	981	62
8615SW	20.90 [302]	21.50 [318]	2.26	1013	64

Decorative Grate Options (Load Classifications are per DIN EN1433)

- BCD Bronze Circular Decorative Grate - Class A
- BDD Bronze Diagonal Decorative Grate - Class A
- DCD Ductile Iron Circular Decorative Grate - Class C
- DDD Ductile Iron Diagonal Decorative Grate - Class A
- DOG Ductile Iron Decorative Grate - Class A
- DWV Ductile Wave Decorative Grate - Class A
- GMG Galvanized Steel Mesh Grate - Class A
- HPB Heel-Proof Bronze Slotted Grate - Class A
- HPS Heel-Proof Stainless Steel Slotted Grate - Class A
- SCD Stainless Steel Circular Decorative Grate - Class B
- SDD Stainless Steel Diagonal Decorative Grate - Class B
- SMG Stainless Steel Mesh Grate - Class A
- SOG Stainless Steel Decorative Grate - Class B

REV. A DATE: 05/06/11 C.N. NO. 121240
 DWG. NO. 302017 PRODUCT NO. Z886-HD-LD-SW

*REGULARLY FURNISHED UNLESS OTHERWISE SPECIFIED