



Z154-E

12 [305] SQUARE TOP PROM-DECK DRAIN W/
 STATIC EXTENSION, HEEL-PROOF GRATE AND
 ROTATABLE FRAME

SPECIFICATION SHEET

TAG _____

Dimensional Data (inches and [mm]) are Subject to Manufacturing Tolerances and Change Without Notice

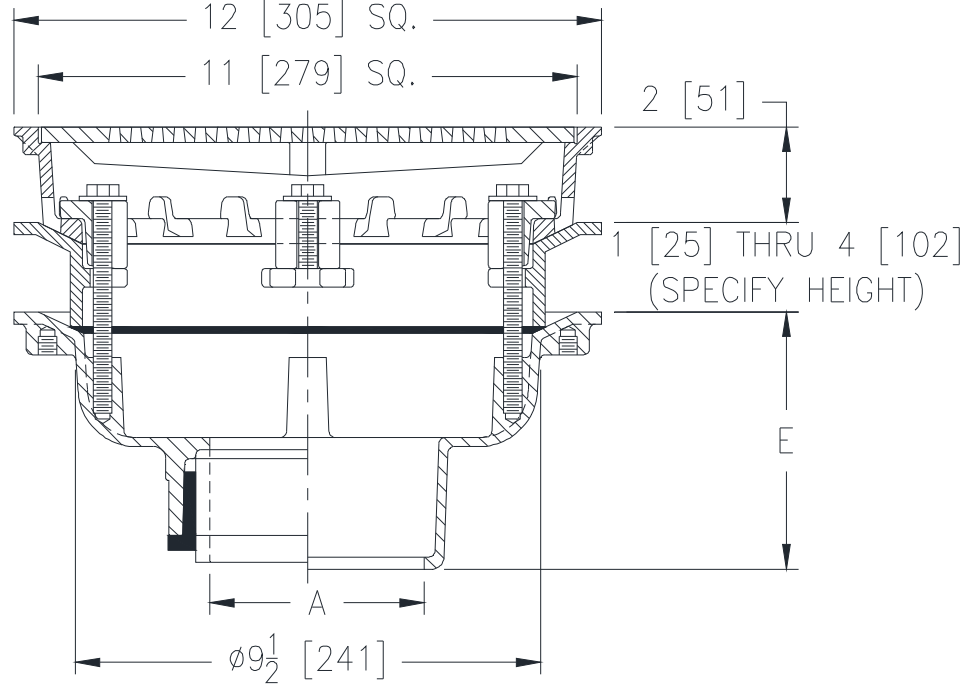

A Pipe Size In. [mm]	Approx. Wt. Lbs. [kg]	Grate Open Area Sq. In. [cm ²]
2, 3, 4, 6 [51, 76, 102, 152]	35 [16]	34 [219]

ENGINEERING SPECIFICATION: ZURNZ154-E

12" [305mm] Square top Prom-Deck drain, Dura-Coated cast iron body with rotatable square promenade frame with seepage slots, frame clamps, light duty heel-proof grate and static extension with gasket.

OPTIONS (Check/specify appropriate options)

PIPE SIZE

- 2, 3, 4, 6 [51, 76, 102, 152]
- 2, 3, 4, 6 [51, 76, 102, 152]
- 2, 3, 4, 6 [51, 76, 102, 152]
- 2, 3, 4 [51, 76, 102]

(Specify size/type) **OUTLET**

- ___ IC Inside Caulk
- ___ IP Threaded
- ___ NH No-Hub
- ___ NL Neo-Loc

'E' BODY HT. DIM.

- 5-1/4 [133]
- 3-3/4 [95]
- 5-1/4 [133]
- 4-9/16 [116]

PREFIXES

- ___ Z D.C.C.I. Body with Top*
- ___ ZB D.C.C.I. Body with Polished Bronze Top (Add 3/16 [5] to 2 [51] Dim. & 5/8 [16] to 12 [305] Dim.)
- ___ ZN D.C.C.I. Body with Polished Nickel Bronze Top (Add 3/16 [5] to 2 [51] Dim. & 5/8 [16] to 12 [305] Dim.)

SUFFIXES

- | | |
|--|--|
| ___ -AR Acid Resistant Epoxy Coated | ___ -SC Secondary Clamp Collar |
| ___ -C Underdeck Clamp | ___ -TC Neo-Loc Test Cap Gasket |
| ___ -DG Duresist Grate (Z Only) | (2,3,4 [51,76,102] NL Bottom Outlet Only) |
| ___ -DP Top-Set® Roof Deck Plate | ___ -TS Top Secured with Slotted Screws |
| ___ -DT Decorative Polished Top (ZB and ZN Only) | ___ -VP Vandal-Proof Secured Top |
| ___ -EB Top-Set® Adjustable Extension Assembly | ___ -Y Sediment Bucket |
| ___ -G Galvanized Cast Iron | ___ -85 Stainless Steel Perforated Extension |
| ___ -S Secondary Strainer | ___ -90 90° Threaded Side Outlet Body |
| | (2,3,4 [51,76,102]) |

* Regularly furnished unless otherwise specified.