



Z100-223

SPECIFICATION SHEET

15 [381] DIAMETER MAIN ROOF DRAIN W/ FLUSH GRATE AND STABILIZER PLATE

TAG _____

Dimensional Data (inches and [mm]) are Subject to Manufacturing Tolerances and Change Without Notice

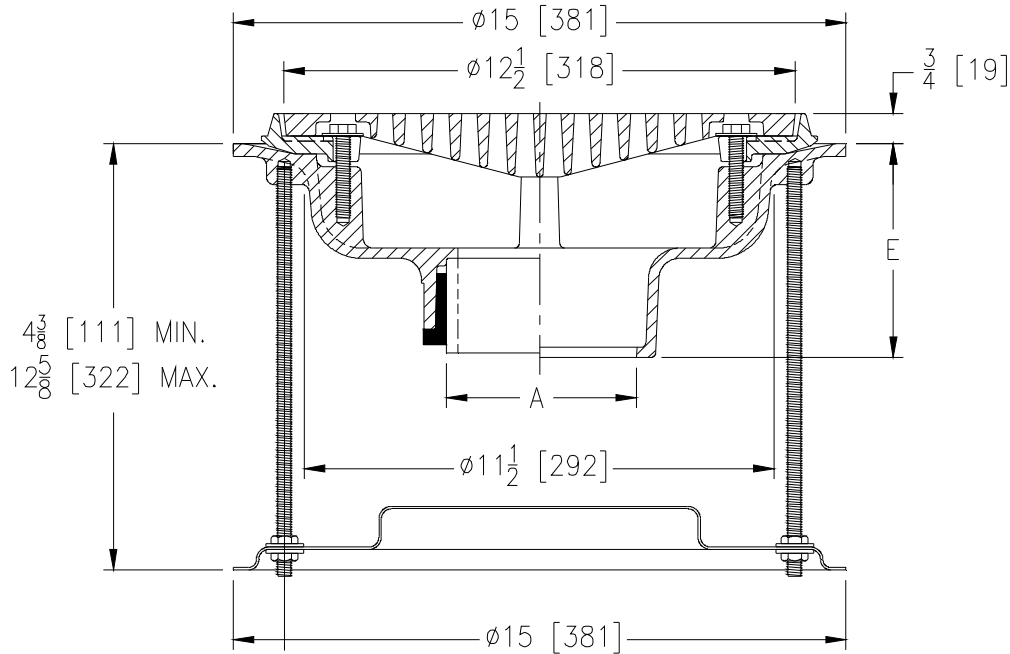

A Pipe Size In.	Approx. Wt. Lbs. [kg]	Grate Open Area Sq. In. [cm ²]
2,3,4 [51,76,102]	26 [12]	32 [206]
5,6 [127,152]	27 [12]	
8 [203]	28 [13]	

ENGINEERING SPECIFICATION: ZURN Z100-223

15 [381] Diameter roof drain. Dura-Coated cast iron body with combination membrane flashing clamp/gravel guard and flush grate. Complete with Z1036 stabilizer plate.

OPTIONS (Check/specify appropriate options)

PIPE SIZE

2 thru 6,8 [51 thru 152,203]
2,3,4 [51,76,102]
6 [152]

(Specify size/type) OUTLET

_____ NH No-Hub
_____ NL Neo-Loc
_____ NL Neo-Loc

E BODY HT. DIM.

5 1/4 [133]
4 9/16 [116]
5 7/16 [112]

PREFIXES

_____ Z D.C.C.I. Body and Grate*

SUFFIXES

_____ -AR Acid Resistant Epoxy Coated
_____ -DX Dex-o-tex Flange
_____ -E Static Extension 1 [25] thru 4 [102] (Specify Ht.)
_____ -EA Adjustable Extension Assembly
2 1/8 [54] thru 3 1/2 [89]
_____ -G Galvanized Cast Iron
_____ -TC Neo-Loc Test Cap Gasket
(2 - 4 [51 - 102] NL Bottom Outlet Only)
_____ -VP Vandal-Proof Secured Top
_____ -84 Stainless Steel Perforated Gravel Guard

REV. DATE: 4/14/10 C.N. NO. 111012

DWG. NO. 84597 PRODUCT NO. Z100-223

*REGULARLY FURNISHED UNLESS OTHERWISE SPECIFIED

ZURN INDUSTRIES, LLC ♦ SPECIFICATION DRAINAGE OPERATION ♦ 1801 Pittsburgh Ave. ♦ Erie, PA 16514

Phone: 814/455-0921 ♦ Fax: 814/454-7929 ♦ World Wide Web: www.zurn.com

In Canada: ZURN INDUSTRIES LIMITED ♦ 3544 Nashua Drive ♦ Mississauga, Ontario L4V1L2 ♦ Phone: 905/405-8272 Fax: 905/405-1292