



# Z100-276

SPECIFICATION SHEET

## 15 [381] DIAMETER MAIN ROOF DRAIN W/ CAST IRON DOME & MULTIPLE EXTENSIONS

TAG \_\_\_\_\_

Dimensional Data (inches and [mm]) are Subject to Manufacturing Tolerances and Change Without Notice

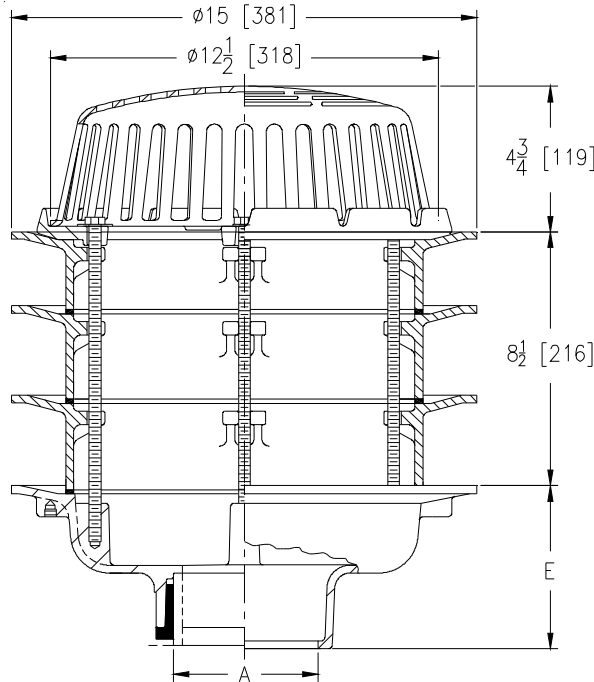

A Pipe Size In.	Approx. Wt. Lbs. [kg]	Dome Open Area Sq. In. [cm <sup>2</sup> ]
2,3,4 [51,76,102]	26 [12]	103 [665]
5,6 [127,152]	27 [12]	
8 [203]	28 [13]	

### ENGINEERING SPECIFICATION: ZURN Z100-276

15 [381] Diameter roof drain. Dura-Coated cast iron body with combination membrane flashing clamp/gravel guard, static extensions and low silhouette cast iron dome.

### OPTIONS (Check/specify appropriate options)

#### PIPE SIZE

- 2 thru 6,8 [51 thru 152,203]
- 2 thru 6,8 [51 thru 152,203]
- 2 thru 6,8 [51 thru 152,203]
- 2,3,4 [51,76,102]

#### (Specify size/type) OUTLET

- \_\_\_\_\_ IC Inside Caulk
- \_\_\_\_\_ IP Threaded
- \_\_\_\_\_ NH No-Hub
- \_\_\_\_\_ NL Neo-Loc

#### E BODY HT. DIM.

- 5-1/4 [133]
- 3-3/4 [95]
- 5-1/4 [133]
- 4-5/8 [117]

#### PREFIXES

- \_\_\_\_\_ Z D.C.C.I. Body with Poly-Dome
- \_\_\_\_\_ ZA D.C.C.I. Body with Aluminum Dome
- \_\_\_\_\_ ZC D.C.C.I. Body with Cast Iron Dome\*
- \_\_\_\_\_ ZRB D.C.C.I. Body with Plain Bronze Dome

#### SUFFIXES

- |   |   |
|---|---|
| _____ -AC Angular Underdeck Clamp   | _____ -SC Secondary Clamp Collar                  |
| _____ -AR Acid Resistant Epoxy Coated   | _____ -SS Stainless Steel Mesh Screen Over Dome   |
| _____ -AW 3/4 [19] to 4 [102] Adj. Water Level Regulator<br>(Specify Height) (ZC Only)                        | _____ -VP Vandal-Proof Secured Top                |
| _____ -BS Bronze Mesh Screen Over Dome  | _____ -W2 2 [51] Internal Water Dam               |
| _____ -C Underdeck Clamp  | _____ -W3 3 [76] Internal Water Dam               |
| _____ -DX Dex-o-tex Flange  | _____ -W4 4 [102] Internal Water Dam              |
| _____ -FG Flush Grate (Replaces Dome Strainer)  | _____ -XJ Vertical Expansion Joint (See Z190)     |
| _____ -G Galvanized Cast Iron   | _____ -84 Stainless Steel Perforated Gravel Guard |
| _____ -GD Galvanized Cast Iron Dome (ZC Only)   | _____ -89 2 [51] High External Water Dam          |
| _____ -HD 6-3/4 [171] High Aluminum Dome Strainer<br>(148 Sq. In. [955 cm <sup>2</sup> ] Open Area) (ZA Only) |   |
| _____ -R Roof Sump Receiver   |   |

\*REGULARLY FURNISHED UNLESS OTHERWISE SPECIFIED

REV. DATE: 08/09/13 C.N. NO. 129765

PROD./DWG. NO. Z100-276

ZURN INDUSTRIES, LLC ♦ SPECIFICATION DRAINAGE OPERATION ♦ 1801 Pittsburgh Ave. ♦ Erie, PA 16514

Phone: 814/455-0921 ♦ Fax: 814/454-7929 ♦ World Wide Web: www.zurn.com

In Canada: ZURN INDUSTRIES LIMITED ♦ 3544 Nashua Drive ♦ Mississauga, Ontario L4V1L2 ♦ Phone: 905/405-8272 Fax: 905/405-1292