



Z-1186-103 OIL INTERCEPTOR

SPECIFICATION SHEET

TAG _____

Dimensional Data (inches and [mm]) are Subject to Manufacturing Tolerances and Change Without Notice

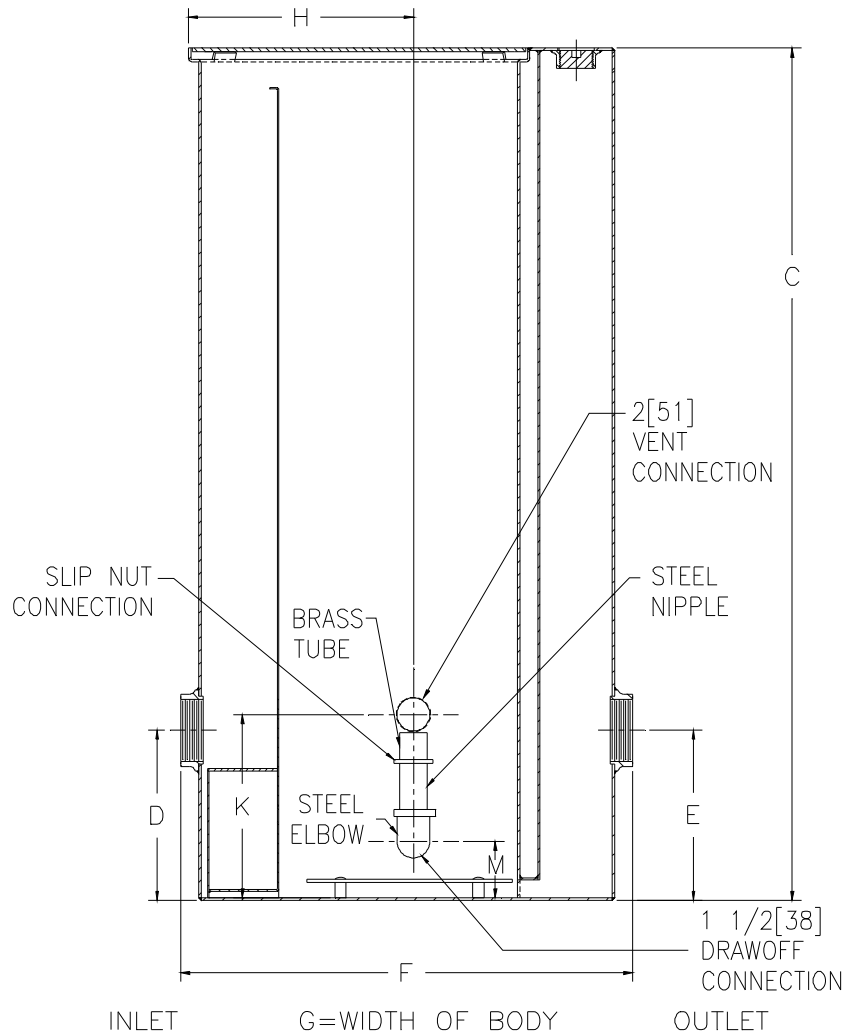

Size	Inlet/ Outlet Size **	Flow Rate GPM [L]	Water Cap. Gal. [L]	Approx. Wt.Lbs. [kg]	Dimensions In Inches						
					C	D/E	F	G	H	K	M
700	3 [75]	35 [132]	21 [79]	140 [64]	47 [1194]	12-1/2 [318]	32-1/4 [819]	19-7/8 [505]	16-3/8 [416]	16-3/4 [425]	6-7/16 [164]

ENGINEERING SPECIFICATION: ZURN Z-1186-103 Fabricated Stainless Steel oil interceptor, bronze cleanout plug and visible double wall trap seal, removable combination pressure equalizing/flow diffusing baffle and sediment bucket, horizontal baffle, adjustable oil drawoff and vent connections either side, secured gasketed non-skid cover, complete with flow control fitting. Regularly furnished with inlet and outlet in high position.

OPTIONS (Check/specify appropriate options)

PREFIXES

___ ZS- Fabricated Stainless Steel*

** Inlet and outlet sizes shown indicate standard operating sizes and flow control setting. Size #700 and will have 4 [102] connections reduced to 3 [76] as standard.

REV.	DATE: 4/21/99	C.N. NO. 80294
DWG. NO. P-14709 PRODUCT NO. Z-1186-103		

*REGULARLY FURNISHED UNLESS OTHERWISE SPECIFIED