



# Z1761-86

## 24 x 16 [610 x 305] KETTLE DRAIN W/ 17 [432] SUMP DEPTH, ANCHOR FLANGE, BAR GRATE & PERFORATED SECONDARY STRAINER

SPECIFICATION SHEET

TAG \_\_\_\_\_

Dimensional Data (inches and [ mm ]) are Subject to Manufacturing Tolerances and Change Without Notice

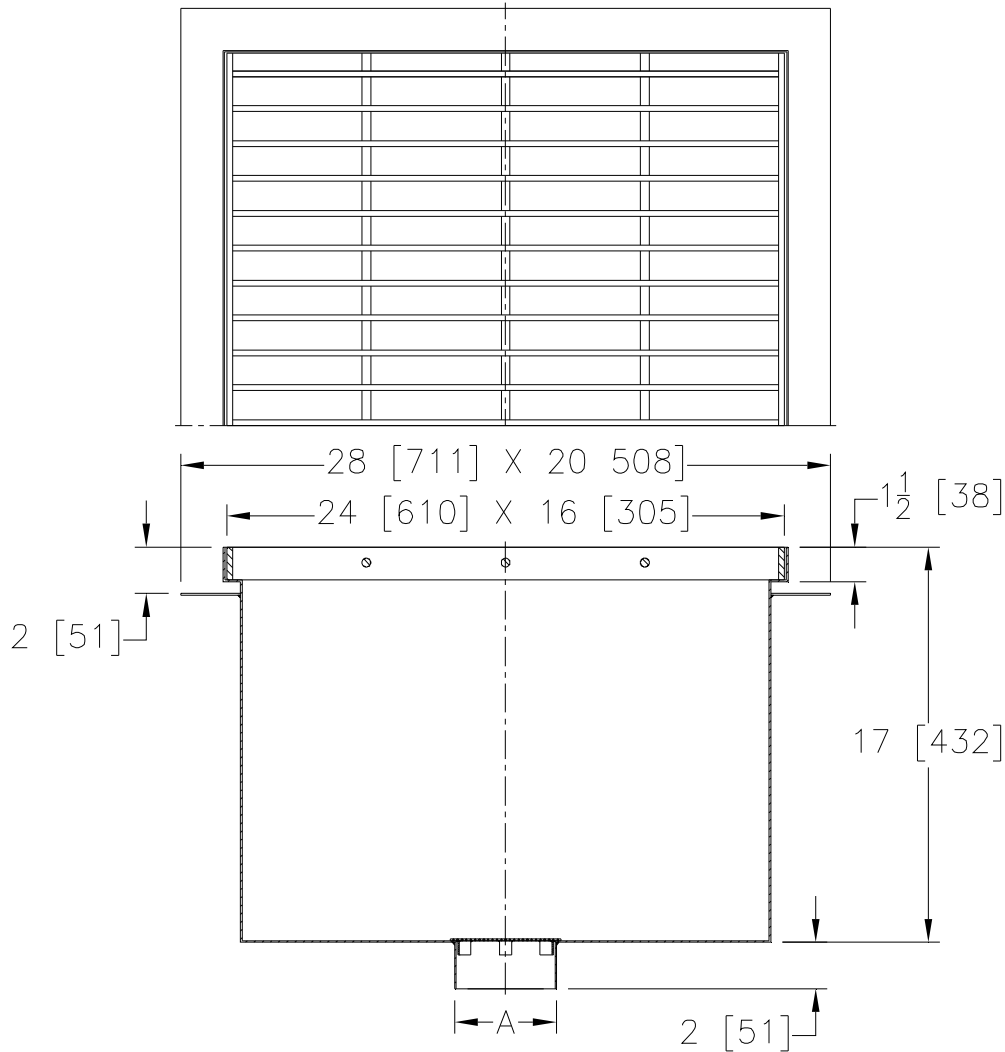

A Pipe Size In.	Approx. Wt. Lbs. [kg]
4-6-8[102-152-203]	54 [24]

**ENGINEERING SPECIFICATION: ZURN ZS1761-86**  
24 X 16 [610 x 305] x 17 [432] deep, 14 gage, All Type 316 Stainless Steel Kettle Drain with, heavy-duty bar grate and perforated secondary strainer.

**OPTIONS** (Check/specify appropriate options)

**PIPE SIZE** (Specify size) **OUTLET**  
4-6-8[102-152-203] \_\_\_\_\_ NH No-Hub

**PREFIXES**  
\_\_\_\_\_ ZM Type 316 (CF8M) Stainless Steel Body and Bar Grate\*

**SUFFIXES**  
\_\_\_\_\_ -PB Perforated Sediment Bucket

REV.	DATE: 4/17/09	C.N. NO. 99915
DWG. NO. P-15699 PRODUCT NO. Z1761-86		

\*REGULARLY FURNISHED UNLESS OTHERWISE SPECIFIED