



Z1170-134
GREASE INTERCEPTOR W/EXTENDED ADJUSTABLE
ENCLOSED RECESSING RECEIVER
W/ANCHOR FLANGE AND CLAMP COLLAR

SPECIFICATION SHEET

TAG _____

Dimensional Data (inches and [mm]) are Subject to Manufacturing Tolerances and Change Without Notice

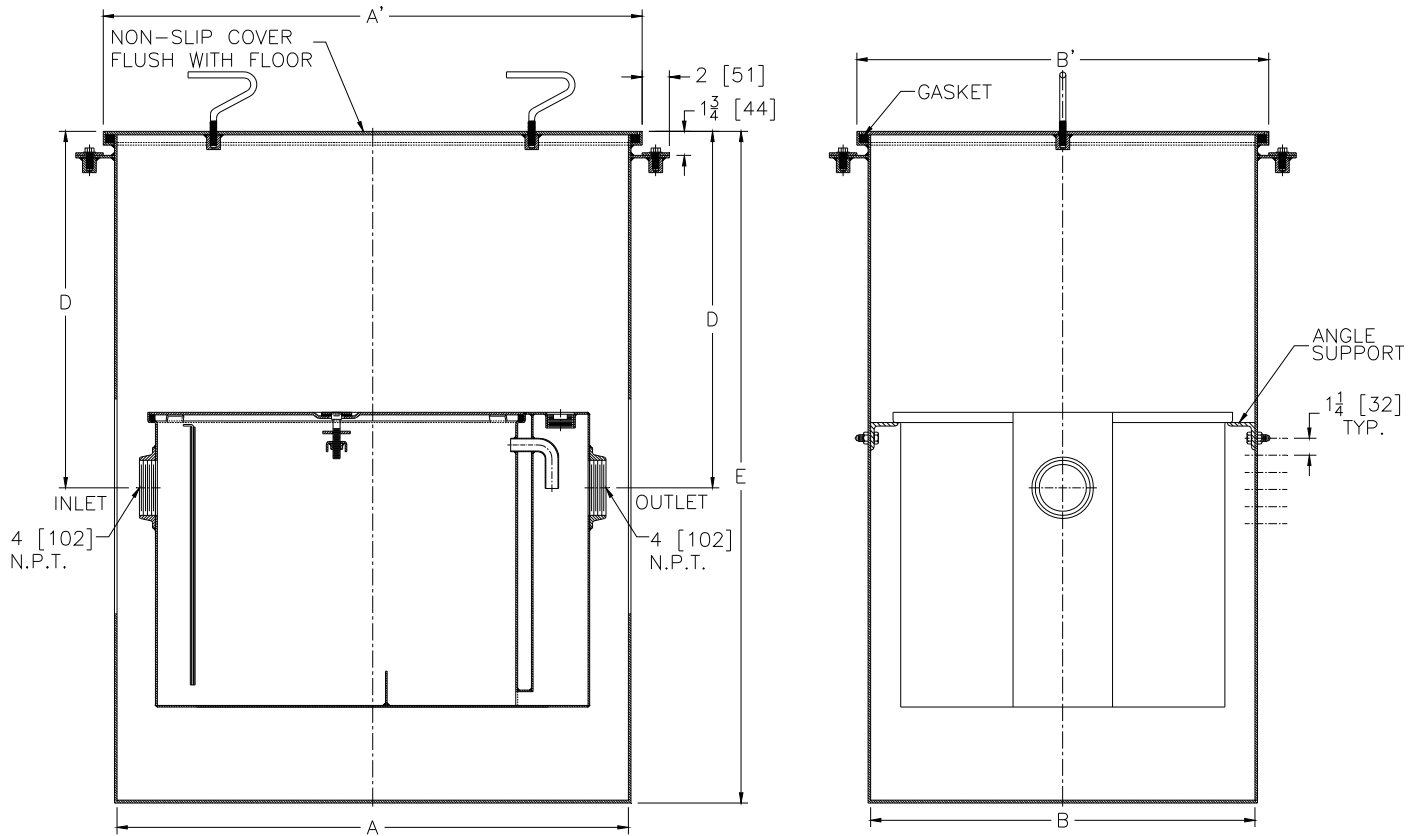

Size	Dimensions In Inches [mm]					
	A	A'	B	B'	D	E
800	37 1/4 [946]	39 1/4 [997]	28 [711]	30 [762]	26 [660]	49 [1245]

ENGINEERING SPECIFICATION: ZURN Z1170-134

Acid Resistant Epoxy Coated Recessing receiver, enclosed type, equipped with integral extension, anchor flange with clamp collar, adjustable support brackets and gasketed non-skid cover with removable lift handles. Complete with #800 Z1170 Grease Interceptor. For interceptor specifications see Z1170 specification sheet.

PREFIXES

_____ **Z** Acid Resistant Coated Fabricated Steel*

SUFFIXES

_____ **-T** Cover recessed for tile/terrazzo. A 3 [76] minimum extension height is required. (Specify required recess depth - 1/8 [3], 3/4 [19], or 1-1/4 [32]).

REV.	DATE: 11/10/09	C.N. NO. 110406
DWG. NO. P-15798	PRODUCT NO. Z1170-134	

*REGULARLY FURNISHED UNLESS OTHERWISE SPECIFIED