



Z-541-112

SPECIFICATION SHEET

12" [305] HEAVY DUTY DRAIN WITH EXTENSION & SUR-SET BUCKET

TAG _____

Dimensional Data (inches and [mm]) are Subject to Manufacturing Tolerances and Change Without Notice

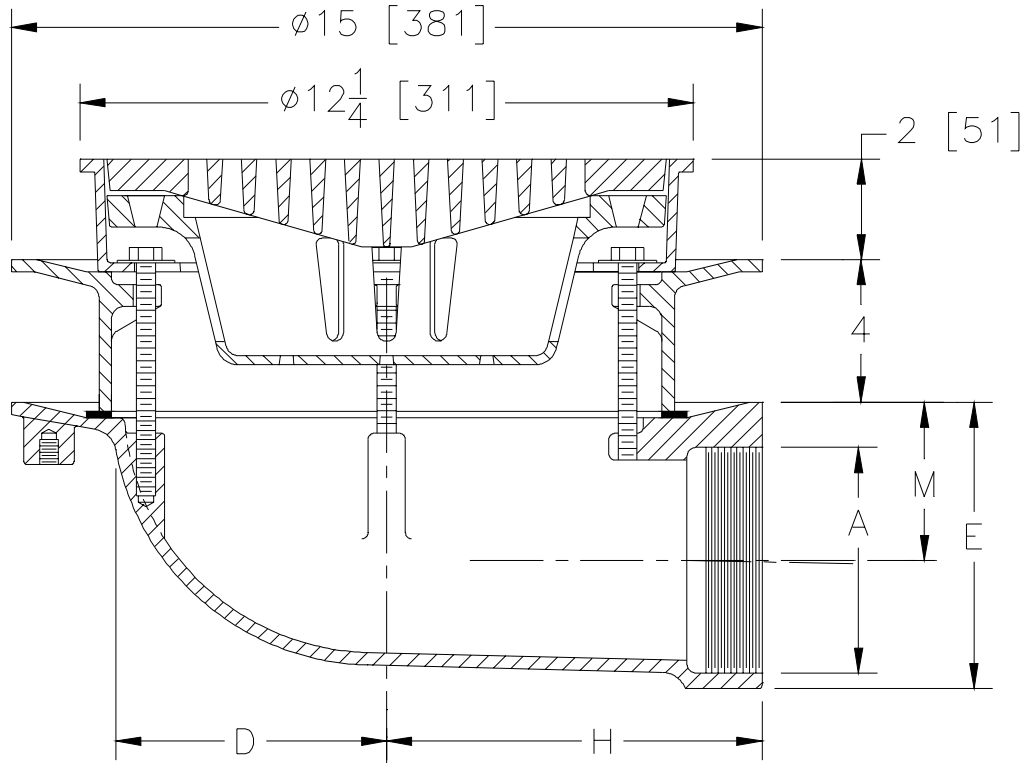

Dimensions in Inches				Approx. Wt. Lbs.	Grate Open Area Sq. In.
A- Pipe Size	D	H	M		
2 [51]	5-7/8 [149]	7-1/2 [191]	4-1/4 [108]	60 [27]	30 [194]
3 [76]			3-11/16 [94]	59 [27]	
4 [102]			3-3/16 [81]	57 [26]	
5 [127]			4-13/16 [122]	70 [32]	
6 [152]			4-1/4 [108]	60 [27]	

ENGINEERING SPECIFICATION: ZURN Z-541-112 12" [305] Diameter top heavy duty drain, Dura-Coated cast iron body with side outlet, seepage pan and combination membrane flashing clamp and frame for heavy duty cast iron loose slotted grate with extension and suspended sediment bucket.

OPTIONS (Check/specify appropriate options)

OUTLET (Specify type)

- ___ IP Threaded
- ___ IP Threaded

PIPE SIZE (Specify size)

- ___ 2", 3", 4" [51, 76, 102]
- ___ 5", 6" [127, 152]

'E' BODY HT. DIMENSION

- 5-3/4" [146]
- 7-7/8" [200]

PREFIXES

- ___ Z- D.C.C.I. Body and Grate*
- ___ ZB- D.C.C.I. Body with Polished Bronze Grate (Add 3/16" [5] to 2" [51] Dim.)
- ___ ZN- D.C.C.I. Body with Polished Nickel Bronze Grate (Add 3/16" [5] to 2" [51] Dim.)

SUFFIXES

- ___ -DG Duresist Grate
- ___ -DX Dex-o-tex Flange (See Z-532)
- ___ -G Galvanized Cast Iron
- ___ -S Secondary Strainer
- ___ -SS Stainless Mesh Liner for Bucket
- ___ -VP Vandal Proof Secured Top

REV.	DATE: 6/13/01	C.N. NO. 87688
DWG. NO. P-14831 PRODUCT NO. Z-541-112		

*REGULARLY FURNISHED UNLESS OTHERWISE SPECIFIED

ZURN INDUSTRIES, INC. ♦ SPECIFICATION DRAINAGE OPERATION ♦ 1801 Pittsburgh Ave. ♦ Erie, PA 16514

Phone: 814/455-0921 ♦ Fax: 814/454-7929 ♦ World Wide Web: www.zurn.com

In Canada: ZURN INDUSTRIES LIMITED ♦ 3544 Nashua Drive ♦ Mississauga, Ontario L4V1L2 ♦ Phone: 905/405-8272 Fax: 905/405-1292