



# Z1251-86

CONCEALED ARM SYSTEM  
WALL SUPPORTED W/ 52 [1321] PLATE

SPECIFICATION SHEET

TAG \_\_\_\_\_

Dimensional Data (inches and [ mm ]) are Subject to Manufacturing Tolerances and Change Without Notice

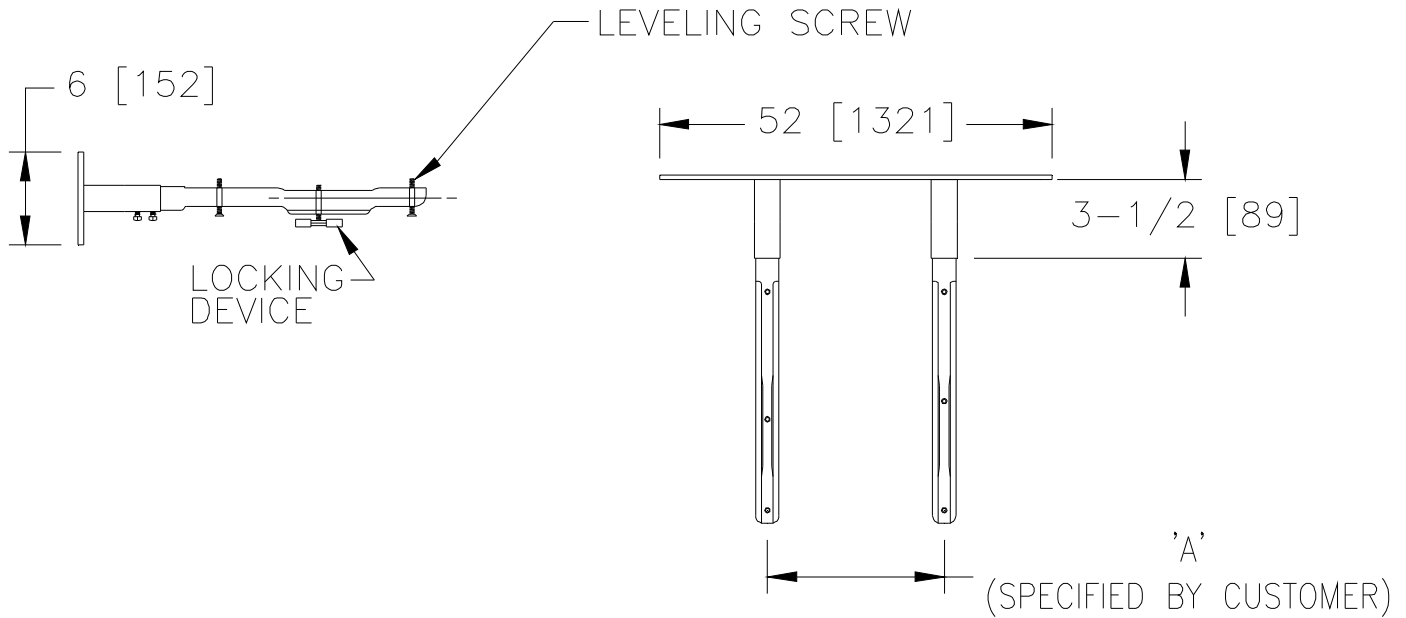

Product No.	Approx. Wt. Lbs. [kg]
Z1251-86	22 [9.5]

**ENGINEERING SPECIFICATION: ZURN Z1251-86**

52" [1321mm] wide lavatory support system with concealed arms. Complete with Dura-Coated 6" [152] wide support plate with integral steel arm sleeves, concealed arms, and mounting fasteners.

**OPTIONS** (Check/specify appropriate options)

**PREFIXES**

\_\_\_ Z Dura-Coated System with Concealed Arms\*

**SUFFIXES**

- \_\_\_ -E2 Concealed Arm Escutcheons 2 [51] Long
- \_\_\_ -E4 Concealed Arm Escutcheons 4 [102] Long
- \_\_\_ -E6 Concealed Arm Escutcheons 6 [152] Long
- \_\_\_ -SL Sleeve Length Over 3-1/2 [89] (Specify Length)
- \_\_\_ -79 Paraplegic Rough-in (7-1/4 [184] sleeves)

\* Regularly furnished unless otherwise specified.