



Z121-DP-90

12 [305] DIAMETER LATERAL ROOF DRAIN
W/ TOP-SET® DECK PLATE

SPECIFICATION SHEET

TAG _____

Dimensional Data (inches and [mm]) are Subject to Manufacturing Tolerances and Change Without Notice

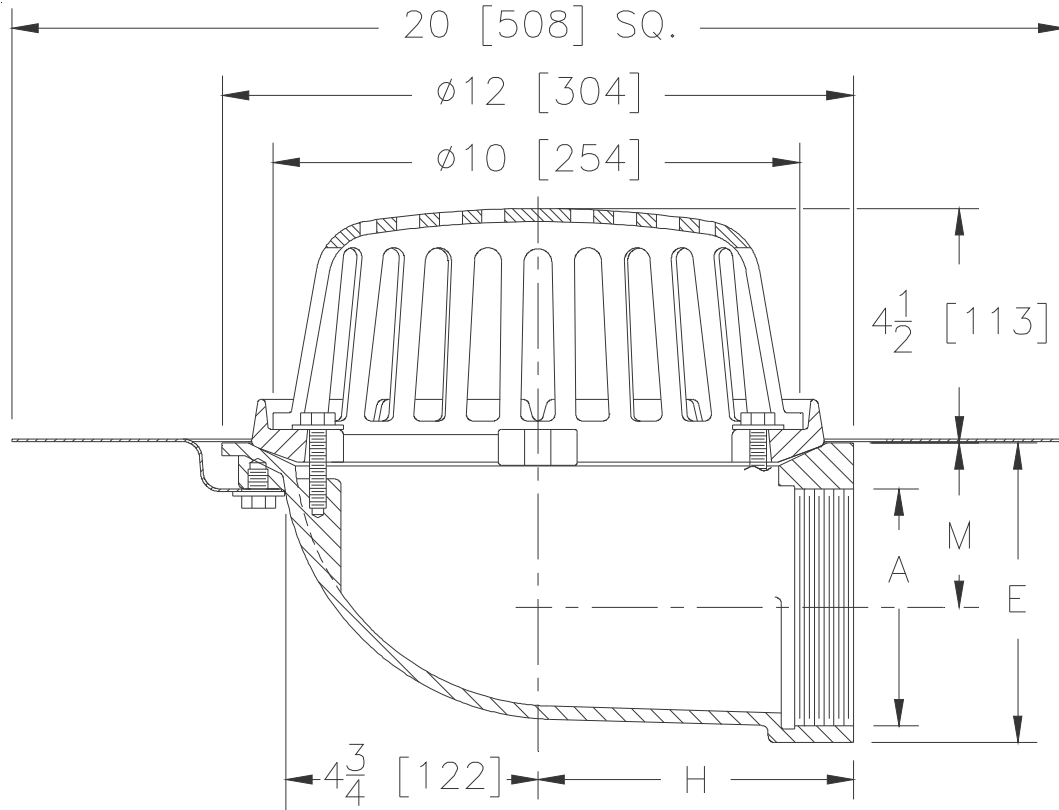

Dimensions In Inches [mm]			Approx. Wt. lbs [kg]	Dome Open Area In ² [cm ²]
A Pipe Size	H	M		
2 [51]	6 [152]	4-1/8 [108]	46 [21]	78 [503]
3 [76]		3-5/8 [94]	44 [20]	
4 [102]		3-1/8 [81]	45 [20]	

ENGINEERING SPECIFICATION: ZURN Z121-DP-90
12" [305mm] Diameter roof drain. Dura-Coated cast iron body with combination membrane flashing clamp/gravel guard, low silhouette Poly-Dome, and Top-Set® deck plate.

OPTIONS (Check/specify appropriate options)

PIPE SIZE

2,3,4 [51,76,102]

(Specify size/type) **OUTLET**

_____ IP Threaded

E BODY HT. DIM.

5-3/4 [133]

PREFIXES

- _____ Z D.C.C.I. Body with Poly-Dome (4-1/4 [108] Dome Height)*
- _____ ZA D.C.C.I. Body with Aluminum Dome (6-9/16 [167] Dome Height)
- _____ ZC D.C.C.I. Body with Cast Iron Dome

SUFFIXES

- _____ -AR Acid Resistant Epoxy Coated
- _____ -E Static Extension 1 [25] thru 4 [102] (Specify Ht.)
- _____ -FG Flush Grate
- _____ -G Galvanized Cast Iron
- _____ -SC Secondary Clamping Collar
- _____ -SS Stainless Mesh Screen Over Dome
- _____ -VP Vandal Proof Secured Top
- _____ -84 Stainless Steel Perforated Gravel Guard
- _____ -85 Stainless Steel Perforated Extension
- _____ -89 2 [51] High External Water Dam

* Regularly furnished unless otherwise specified.