



# Z1910-K

8 X 8 [203 X 203] A.R.E. SANI-FLOR RECEPTOR 6 [152]  
SUMP DEPTH W/ ANCHOR FLANGE

SPECIFICATION SHEET

TAG \_\_\_\_\_

Dimensional Data (inches and [ mm ]) are Subject to Manufacturing Tolerances and Change Without Notice

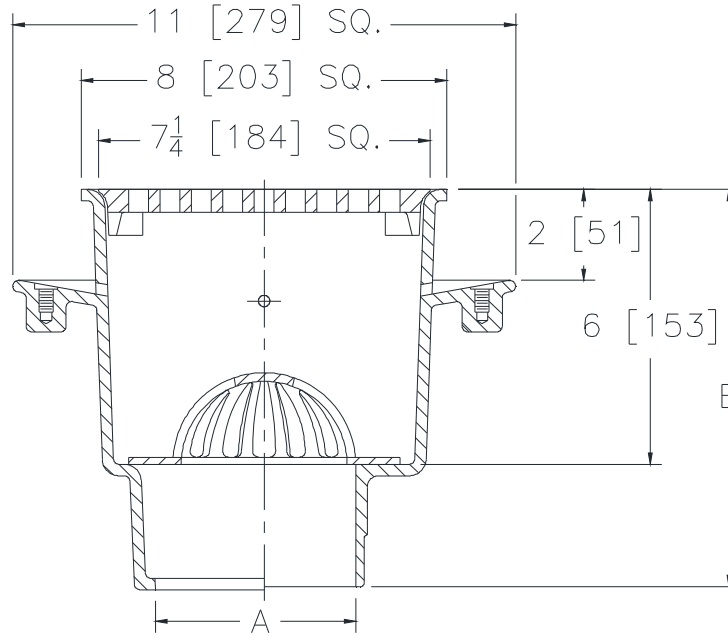

A Pipe Size In [mm]	Approx Wt. Lbs. [kg]	Grate Open Area Sq. In. [cm <sup>2</sup> ]
2,3,4 [51,76,102]	25 [11]	19 [123]

### ENGINEERING SPECIFICATION: ZURNZ1910-K

Sani-Flor Receptor 8" x 8" x 6" [203mm x 203mm x 152mm] deep cast iron body with anchor flange and seepage holes, square, medium-duty grate with 7/16" [11mm] slotted openings, white acid resisting porcelain enamel interior and top, and black ground enamel exterior coating, complete with white ABS anti-splash interior bottom dome strainer.

**OPTIONS** (Check/specify appropriate options)

#### PIPE SIZE

- 3,4 [76,102]
- 2,3,4 [51,76,102]
- 2,3,4 [51,76,102]

(Specify size/type) **OUTLET**

- \_\_\_\_\_ IC Inside Caulk
- \_\_\_\_\_ NH No-Hub
- \_\_\_\_\_ NL Neo-Loc

#### 'E' BODY HT. DIMENSION

Z	ZN
8-3/4 [222]	9-1/4 [235]
8-5/8 [219]	9-1/8 [232]
8 [203]	8-1/2 [216]

#### PREFIXES

- \_\_\_\_\_ Z Cast Iron Body with White A.R.E. Interior\*
- \_\_\_\_\_ ZN Cast Iron Body with White A.R.E. Interior, 8-9/17 [216] Square Nickel Bronze Frame and Full Grate with 5/16 [8] Square Openings (Add 1/2 [13] to 8 [203] and 'E' Dim.)

#### SUFFIXES

- \_\_\_\_\_ -DX Dex-O-Tex Flange (ZN Only)
- \_\_\_\_\_ -LD Less Bottom Dome Strainer
- \_\_\_\_\_ -P 1/2 [13] Trap Primer Connection (See Z1023)
- \_\_\_\_\_ -TC Neo-Loc Test Cap Gasket (2,3,4 [51,76,102] NL Bottom Outlet Only)
- \_\_\_\_\_ -1 Less Grate
- \_\_\_\_\_ -2 1/2 Grate
- \_\_\_\_\_ -3 3/4 Grate
- \_\_\_\_\_ -4 Full Grate with Square Center Opening
- \_\_\_\_\_ -6 Grate w/ 6 [152] Dia. x 6 [152] High Funnel
- \_\_\_\_\_ -8 Grate w/ 8-7/8 x 3-5/8 x 3-3/4 [225 x 92 x 95] High Oval Funnel
- \_\_\_\_\_ -11 Vandal-Proof Secured Grate (ZN Only)
- \_\_\_\_\_ -15 Solid Loose Set Cover
- \_\_\_\_\_ -19 Full Hinged Grate (ZN Only)
- \_\_\_\_\_ -23 Aluminum Bucket
- \_\_\_\_\_ -25 White A.R.C. Bucket
- \_\_\_\_\_ -31 Stainless Steel Mesh Liner for Bucket
- \_\_\_\_\_ -32 Aluminum Dome Strainer
- \_\_\_\_\_ -33 White A.R.C. Anti-Splash Bottom Dome Strainer

\* Regularly furnished unless otherwise specified.

Zurn Industries, LLC | Specification Drainage Operation  
1801 Pittsburgh Avenue, Erie, PA U.S.A. 16502 · Ph. 855-663-9876, Fax 814-454-7929  
In Canada | Zurn Industries Limited  
3544 Nashua Drive, Mississauga, Ontario L4V 1L2 · Ph. 905-405-8272, Fax 905-405-1292  
[www.zurn.com](http://www.zurn.com)

Rev. E  
Date: 10/12/17  
C.N. No. 138771  
Prod. | Dwg. No. Z1910-K