



Z717-HDG

SPECIFICATION SHEET

17 [432] WIDE FRAME AND GRATE SYSTEM WITH GALVANIZED FRAME

TAG _____

Dimensional Data (inches and [mm]) are Subject to Manufacturing Tolerances and Change Without Notice

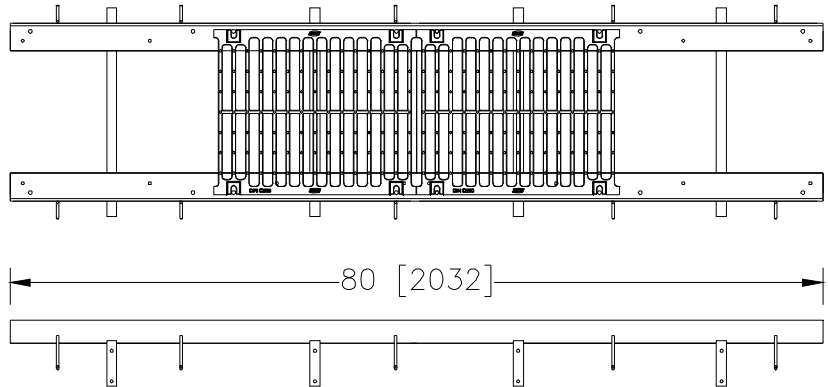
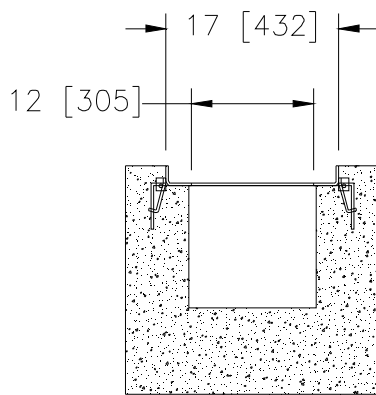

SPECIFYING ENGINEER IS RESPONSIBLE FOR CONCRETE ENCASEMENT AND REINFORCING BASED UPON APPLICATION AND LOCAL CODES

ENGINEERING SPECIFICATION: Zurn Z717-HDG Frame and Grate System shall be 80 [2032] long, 17 [432] wide reveal and have a 12-1/2 [318] clear opening. Shall come with clips attached to the frame to accommodate vertical re-bar for positioning and anchoring purposes. Shall mechanically lock into the concrete surround every 10 [254]. Shall be provided with the standard GDC grate, Zurn 16-1/4 [413] wide Galvanized Ductile Slotted Grate, which locks down to the frame with 4 contiguous bolt anchors per grate. Ductile Iron conforms to ASTM specification A536-84, Grade 80-55-06, and Galvanizing conforms to ASTM specification A123. Galvanized Ductile Iron grate is rated class C per the DIN EN1433 top load classifications. Supplied in 20 [608] nominal lengths with 13/16 [21] wide slots, and 1-3/4 [44] bearing depth. Grate has an open area of 118 sq. in. per ft. [249779 sq. mm per meter]. The 1/4 [6] thick Galvanized Carbon Steel Frame Assembly conforms to ASTM specification A36 and Galvanizing conforms to ASTM specification A123 with 10 - 4 [102] long concrete anchors per 80 [2032]. All welds must be performed by a certified welder per ASTM standard AWS D1.1. Frames shall be produced in the USA.

PREFIX OPTIONS (Check/specify appropriate options)

Z 80 [2032] Heavy-Duty Galvanized Frame with Anchor Studs*

SUFFIX OPTIONS (Check/specify appropriate options)

Grate Options

- DCC Ductile Iron Solid Cover-Class C
- DGC Ductile Iron Slotted Grate-Class C*
- DGF Ductile Iron Slotted Grate-Class F
- GDC Galvanized Ductile Iron Grate-Class C
- GDF Galvanized Ductile Iron Grate - Class F
- GG Fiberglass Grate
- HPD Heel-Proof Longitudonal Ductile Iron Grate - Class C

Miscellaneous Options

- RC Rebar Clip (Set of 2)
- VP Vandal-Proof Lockdown Assembly

MADE in the U.S.A.

- ADA-USA Meets Americans with Disabilities Act Requirements - Class C
- DGC-USA Ductile Iron Slotted Grate-Class C
- DGF-USA Ductile Iron Slotted Grate-Class F
- GADA-USA Galvanized Ductile ADA Slotted Grate - Class C
- GDC-USA Galvanized Ductile Iron Grate-Class C
- GDF-USA Galvanized Ductile Iron Grate - Class F

MADE in the U.S.A. Frame Options

- CBF Black Acid Resistant Coated Top Frame

*REGULARLY FURNISHED UNLESS OTHERWISE SPECIFIED

REV.	DATE: 3/8/11	C.N. NO. 121006
DWG. NO. 304875	PRODUCT NO. Z717-HDG	

ZURN INDUSTRIES, LLC ♦ SPECIFICATION DRAINAGE OPERATION ♦ 1801 Pittsburgh Ave. ♦ Erie, PA 16514

Phone: 814455-0921 ♦ Fax: 814454-7929 ♦ World Wide Web: www.zurn.com

In Canada: ZURN INDUSTRIES LIMITED ♦ 3544 Nashua Drive ♦ Mississauga, Ontario L4V1L2 ♦ Phone: 905405-8272 Fax: 905405-1292