

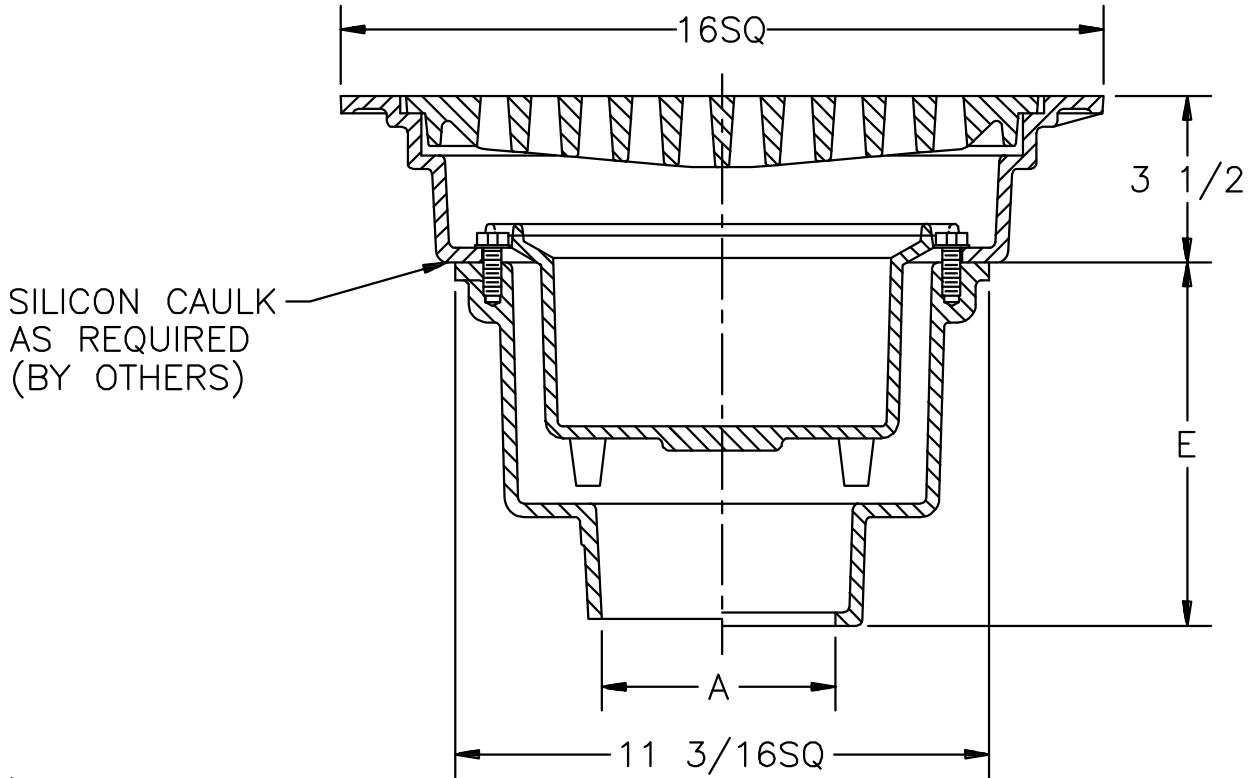

Z-662-77
16" EXTRA HEAVY
DUTY DRAIN

TAG _____

Dimensional Data (inches and [mm]) are Subject to Manufacturing Tolerances and Change Without Notice



| A- Pipe Size In | Approx. Wt. Lbs. | Grate Open Area Sq. In. |
|--------------------|---------------------|----------------------------|
| 3-4 | 84 | 53 |
| 5-6 | 90 | |

ENGINEERING SPECIFICATION: Z-662-77 16" Square top drain, Dura-Coated cast iron body with bottom outlet, seepage pan and combination membrane flashing clamp and frame for extra heavy duty slotted loose grate with suspended sediment bucket.

OPTIONS (Check/specify appropriate options)

OUTLET (Specify type)

- _____ **IC** Inside Caulk
- _____ **IG** Inside Caulk w/Sealtrol Gskt.
- _____ **IP** Threaded
- _____ **NH** No-Hub
- _____ **NL** Neo-Loc

PIPE SIZE (Specify size)

- _____ 3" thru 6"
- _____ 3" 4", 6"
- _____ 3" thru 6"
- _____ (IP w/Z-1040-1)
- _____ 3", 4"

**'E' BODY HT.
DIMENSION**

- 7-3/4"
- 7-3/4"
- 6-3/8"
- 7-1/8"

PREFIXES

- _____ **Z** D.C.C.I. Body and Grate*
- _____ **ZB** D.C.C.I. Body w/Polished Bronze Grate (Add 3/16" to 3-3/8" Dim. & 11/16" to 16" Dim.)
- _____ **ZN** D.C.C.I. Body w/Polished Nickel Bronze Grate (Add 3/16" to 3-3/8" Dim. & 11/16" to 16" Dim.)

SUFFIXES

- _____ **-DG** Duresist Grate
- _____ **-G** Galvanized Cast Iron
- _____ **-LY** (Less) Bucket
- _____ **-SS** Stainless Mesh Liner for Bucket
- _____ **-V** Backwater Valve (See Z-1099)
- _____ **-VP** Vandal Proof Secured Top
- _____ **-Y** Aluminum Sediment Bucket

| | | |
|--|---------------------|-----------------------|
| REV. | DATE: 2/5/93 | C.N. NO. 68864 |
| DWG. NO. P-13792 PRODUCT NO. Z-662-77 | | |

*REGULARLY FURNISHED UNLESS OTHERWISE SPECIFIED