



Z125-SS

8-3/8 [213] DIAMETER ROOF DRAIN W/
STAINLESS STEEL MESH SCREEN OVER DOME

SPECIFICATION SHEET

TAG _____

Dimensional Data (inches and [mm]) are Subject to Manufacturing Tolerances and Change Without Notice

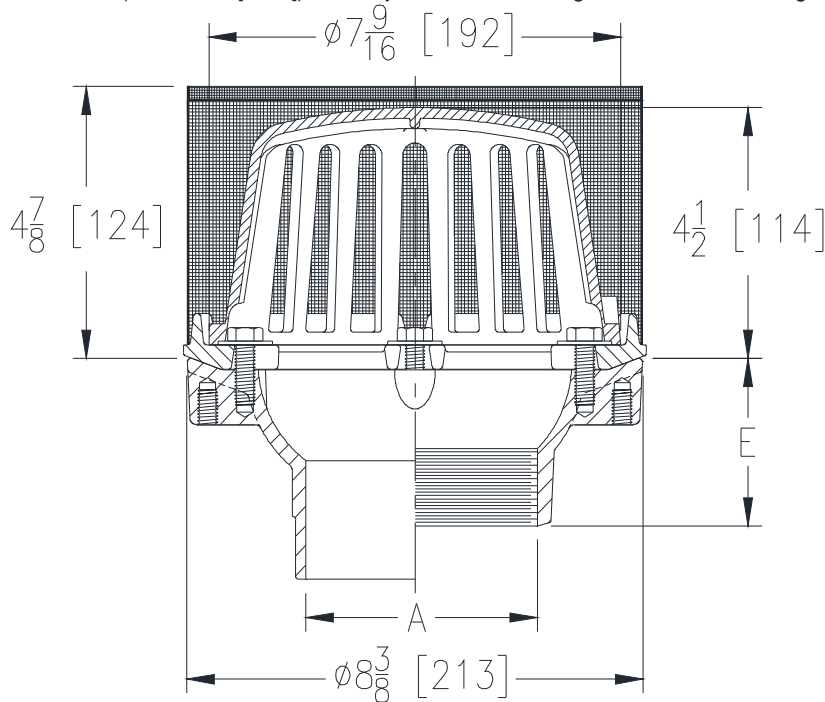

A Pipe Size In. [mm]	Approx. Wt. Lbs. [kg]	Dome Open Area Sq. In. [cm ²]
2,3,4 [51,76,102]	23 [10]	43 [277]

ENGINEERING SPECIFICATION: ZURN Z125-SS

8-3/8" [213mm] Diameter roof drain, Dura-Coated cast iron body with combination membrane flashing clamp/gravel guard, low silhouette Poly-Dome and stainless steel mesh screen.

OPTIONS (Check/specify appropriate options)

PIPE SIZE

- 2,3,4 [51,76,102]
- 2 [51]
- 3 [76]
- 4 [102]
- 2,3,4 [51,76,102]
- 2,3,4 [51,76,102]

(Specify size/type) **OUTLET**

- ___ IC Inside Caulk
- ___ IP Threaded
- ___ IP Threaded
- ___ IP Threaded
- ___ NH No-Hub
- ___ NL Neo-Loc

'E' BODY HT. DIM.

- 3-7/8 [98]
- 2-7/16 [62]
- 2-3/4 [70]
- 3 [76]
- 4 [102]
- 3-13/16 [97]

PREFIXES

- ___ Z D.C.C.I. Body with Poly-Dome (4-1/4 [108] Dome Height)*
- ___ ZA D.C.C.I. Body with Aluminum Dome (4-1/4 [108] Dome Height)
- ___ ZC D.C.C.I. Body with Low Silhouette Cast Iron Dome (4-1/4 [108] Dome Height)

SUFFIXES

- ___ -AR Acid Resistant Epoxy Coated Finish
- ___ -C Underdeck Clamp
- ___ -DP Top-Set® Roof Deck Plate
(Replaces both the -C and -R)
- ___ -E 2 [51] High Static Extension (Specify Height)
- ___ -EB Top-Set® Adjustable Extension Assembly
- ___ -G Galvanized Cast Iron
- ___ -R Roof Sump Receiver
- ___ -SC Secondary Clamping Collar
- ___ -TC Neo-Loc Test Cap Gasket
(2,3,4 [51,76,102] NL Bottom Outlet Only)
- ___ -VP Vandal-Proof Secured Top
- ___ -XJ Vertical Expansion Joint (See Z190)
- ___ -84 Stainless Steel Perforated Gravel Guard
- ___ -85 Stainless Steel Perforated Extension
- ___ -89 2 [51] High External Water Dam
- ___ -90 90° Threaded Side Outlet Body
(2,3,4 [51,76,102])

* Regularly furnished unless otherwise specified.