



Z103-45-DP

15 [381] DIAMETER DEEP SUMP 45° DUAL OUTLET
ROOF DRAIN W/ AND TOP-SET® DECK PLATE

SPECIFICATION SHEET

TAG _____

Dimensional Data (inches and [mm]) are Subject to Manufacturing Tolerances and Change Without Notice

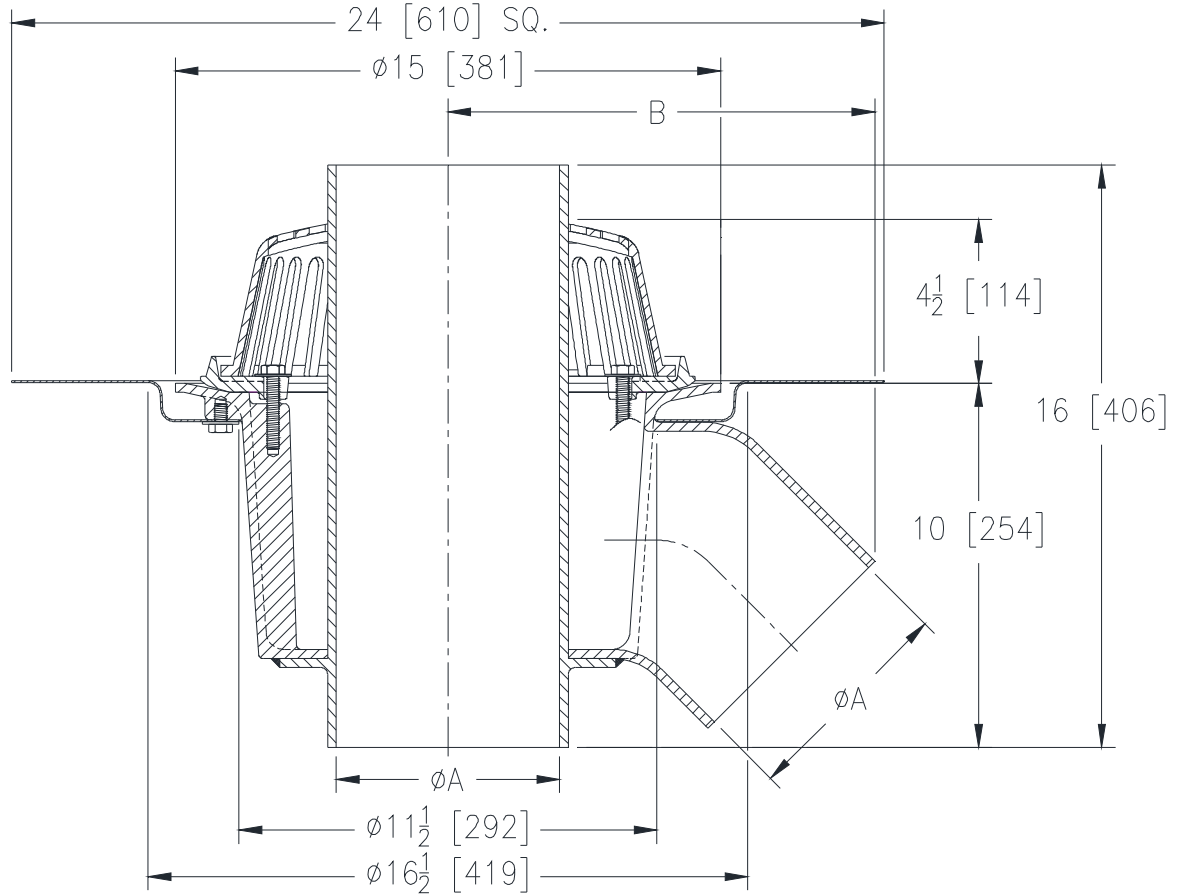

A Pipe Size In. [mm]	B In. [mm]	Approx. Wt. Lbs. [kg]	Dome Open Area Sq. In. [cm ²]
3 [76]	9-7/16 [240]	77 [35]	103 [665]
4 [102]	10-1/4 [260]		
6 [152]	10-15/16 [278]		

ENGINEERING SPECIFICATION: ZURN Z103-45-DP
15" [381mm] Diameter dual outlet roof drain with 45° primary outlet connection. Dura-Coated cast iron deep sump body with combination membrane flashing clamp/gravel guard, overflow pipe (3", 4", 6" [76mm, 102mm, 152mm]), low silhouette cast iron dome and Top-Set® Deck Plate.

OPTIONS (Check/specify appropriate options)

PIPE SIZE

3, 4, 6 [76, 102, 152]

(Specify size) **OUTLET**

_____ NH No-Hub

PREFIXES

_____ Z D.C.C.I. Body w/ Cast Iron Dome

SUFFIXES

_____ -AR Acid Resistant Epoxy Coated Finish
 _____ -DU Cast Iron Dome on Overflow Pipe
 _____ -E Static Extension 1 - 4 [25 - 102] (Specify Ht.)
 _____ -G Galvanized Cast Iron
 _____ -MS Mesh Screen on Overflow Pipe

_____ -SS Stainless Mesh Screen over Dome
 _____ -VP Vandal-Proof Secured Top
 _____ -2OF 2 [51] High Overflow Pipe
 _____ -84 Stainless Steel perforated Gravel Guard

* Regularly furnished unless otherwise specified.