



Z1181-89 SOLIDS INTERCEPTOR

SPECIFICATION SHEET

TAG _____

Dimensional Data (inches and [mm]) are Subject to Manufacturing Tolerances and Change Without Notice

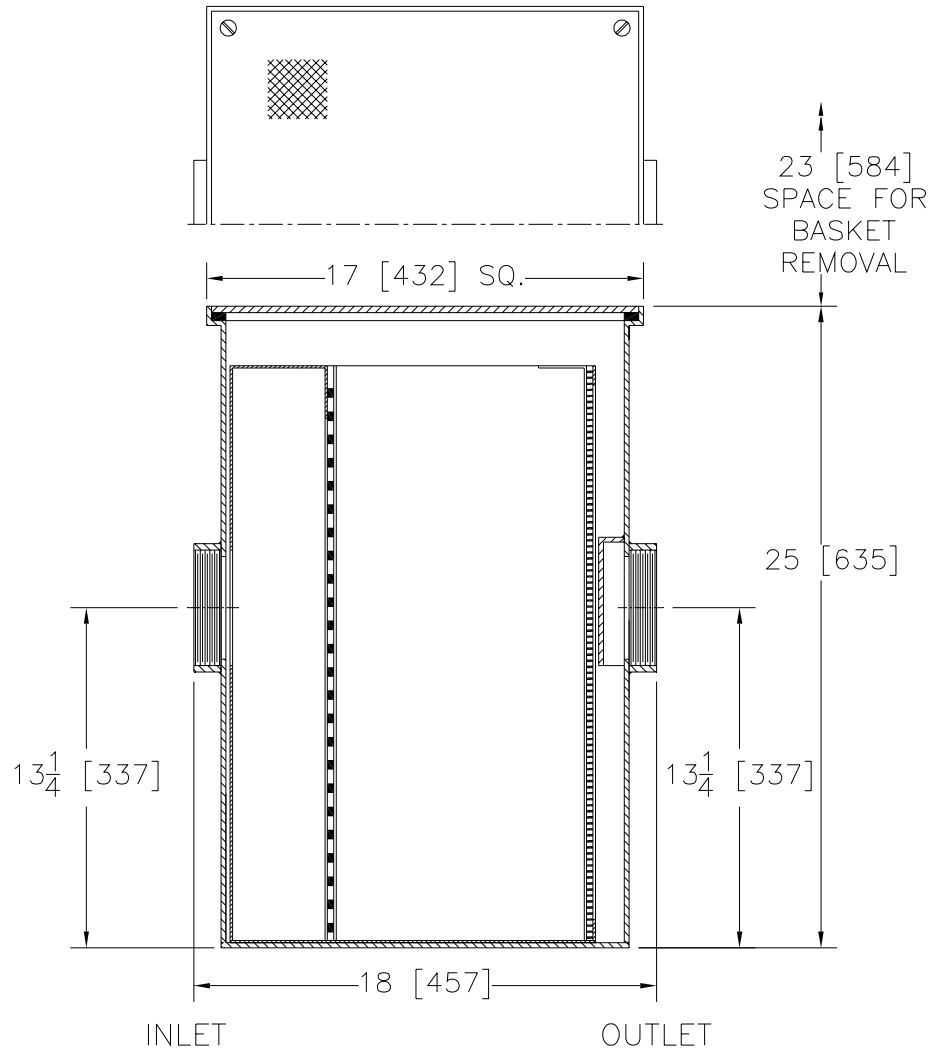

Inlet/Outlet Inches	Flow Rate GPM [L]	Approx. Wt. Lbs. [kg]
4 [102]	100 [378]	42 [19]

ENGINEERING SPECIFICATION: ZURN Z1181-89 Large capacity Acid Resistant Coated fabricated steel solids interceptor, for on-floor or flush with floor installation, with removable primary and secondary flow diffusing/intercepting screens, and sediment bucket, with gasketed non-skid cover. Regularly furnished with 13 1/4 [337] high inlet and high outlet.

OPTIONS (Check/specify appropriate options)

PREFIXES

- ___ Z Acid Resistant Coated Fabricated Steel*
- ___ ZS All Fabricated Type 304 Stainless Steel

SUFFIXES

- ___ -CS Custom Screens (Specify material and perforation size required)
- ___ -SS Stainless Steel Perforated Screens for Bucket (Specify perforation size)
- ___ -YR Replacement Bucket Assembly with Perforated Screens

REV.	DATE: 6/6/06	C.N. NO. 95175
DWG. NO. P-15288 PRODUCT NO. Z1181-89		

*REGULARLY FURNISHED UNLESS OTHERWISE SPECIFIED