



Z662-76

16 [406] DRAIN W/ BAR GRATE

SPECIFICATION SHEET

TAG _____

Dimensional Data (inches and [mm]) are Subject to Manufacturing Tolerances and Change Without Notice

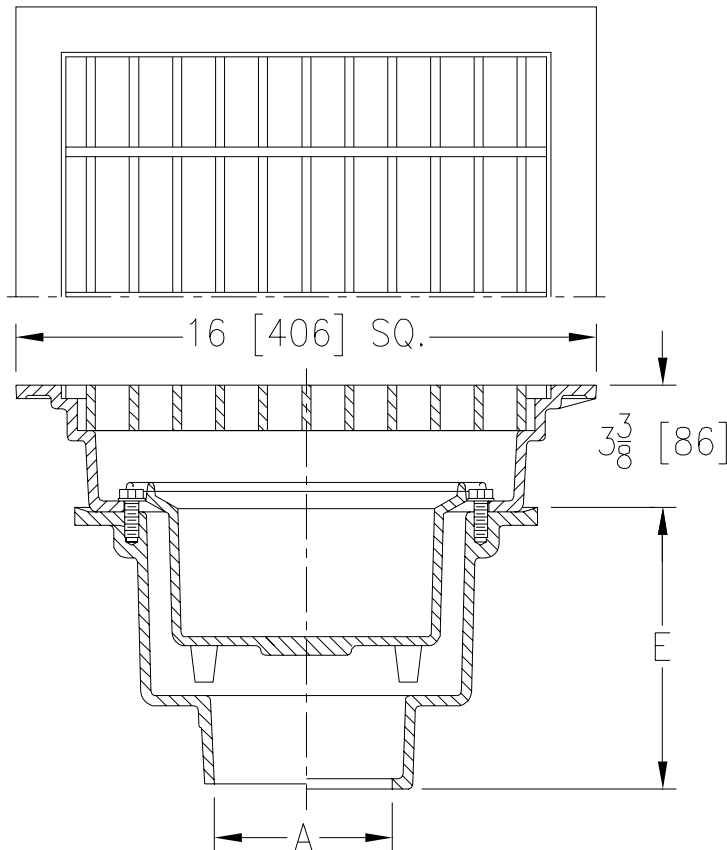

A Pipe Size	Approx. Wt. Lbs. [kg]	Grate Open Area Sq. In. [cm ²]
3 - 4 [76 - 102]	76 [34]	105 [687]
5 - 6 [127 - 152]	73 [33]	

ENGINEERING SPECIFICATION Z662-76

16 [406] Square top drain, Dura-Coated cast iron body with bottom outlet, seepage pan and combination membrane flashing clamp and frame for stainless steel bar grate with suspended sediment bucket.

OPTIONS (Check/specify appropriate options)

PIPE SIZE

- 3 thru 6 [76 thru 152]
- 3 - 4 - 6 [76 - 102 - 152]
- 3 thru 6 [76 thru 152]
(IP w/Z1040-1)
- 3 - 4 [76 - 102]

(Specify size/type) OUTLET

- ___ IC Inside Caulk
- ___ IG Inside Caulk w/Sealtrol Gskt.
- ___ IP Threaded
- ___ NH No-Hub
- ___ NL Neo-Loc

'E' BODY HT. DIM.

- 7 3/4 [197]
- 7 3/4 [197]
- 6 3/8 [162]
- 7 1/8 [181]

PREFIXES

- ___ Z D.C.C.I. Body and Stainless Steel Bar Grate*

SUFFIXES

- ___ -LY (Less) Bucket
- ___ -SS Stainless Mesh Liner for Bucket
- ___ -TC Neo-Loc Test Cap Gasket
(3 - 4 [75 - 102] NL Bottom Outlet Only)
- ___ -V Backwater Valve (See Z1099)
- ___ -YA Aluminum Sediment Bucket
- ___ -90 90° Threaded Side Outlet Body

REV. B DATE: 6/2/06 C.N. NO. 95161

DWG. NO. P-13781 PRODUCT NO. Z662-76

*REGULARLY FURNISHED UNLESS OTHERWISE SPECIFIED

ZURN INDUSTRIES, INC. ♦ SPECIFICATION DRAINAGE OPERATION ♦ 1801 Pittsburgh Ave. ♦ Erie, PA 16514

Phone: 814455-0921 ♦ Fax: 814454-7929 ♦ World Wide Web: www.zurn.com

In Canada: ZURN INDUSTRIES LIMITED ♦ 3544 Nashua Drive ♦ Mississauga, Ontario L4V1L2 ♦ Phone: 905405-8272 Fax: 905405-1292