

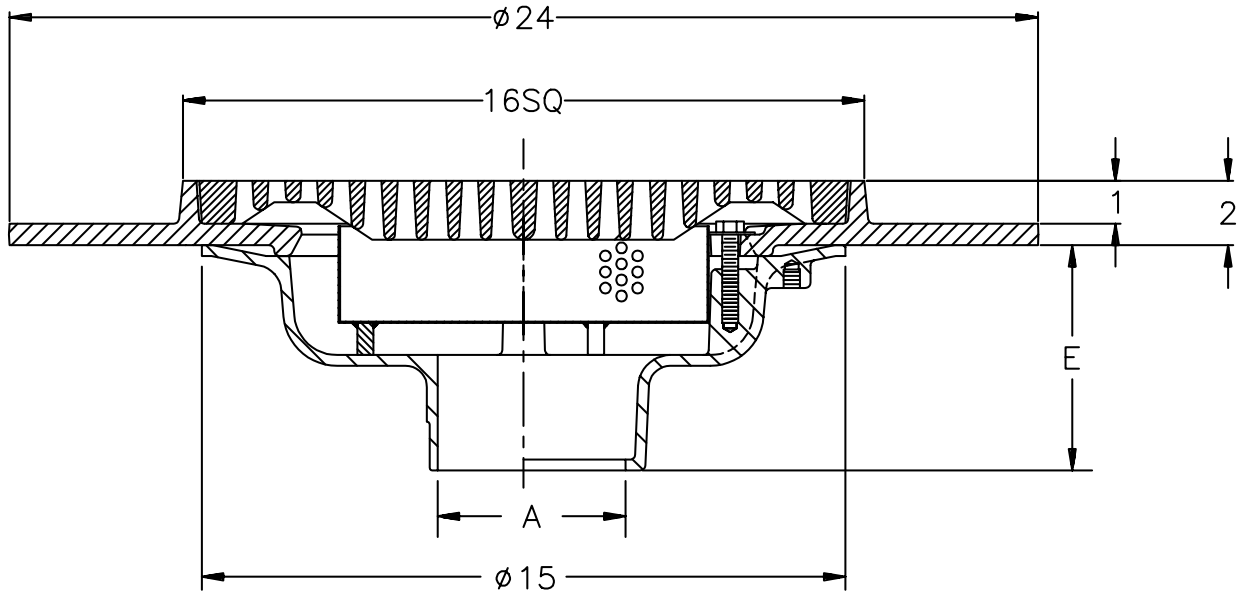

**Z-534-83**  
**16" SQUARE TOP PARKING DECK**  
**DRAIN WITH SUPPORT FLANGE**

TAG \_\_\_\_\_

Dimensional Data (inches and [ mm ]) are Subject to Manufacturing Tolerances and Change Without Notice



A- Pipe Size In.	Approx. Wt. Lbs.	Grate Open Area Sq. In.
2-3-4-5-6	122	84
8-10	124	

**ENGINEERING SPECIFICATION:** ZURN Z-534-83 16" Square Top Parking Deck Drain, Dura-Coated cast iron body with bottom outlet, seepage pan and combination membrane flashing clamp and heavy duty support flange, with heavy duty slotted grate and fabricated bucket.

**OPTIONS** (Check/specify appropriate options)

**OUTLET** (Specify type)

- \_\_\_\_\_ **IC** Inside Caulk
- \_\_\_\_\_ **IG** Inside Caulk w/Sealtrol Gskt.
- \_\_\_\_\_ **IP** Threaded
- \_\_\_\_\_ **NH** No-Hub
- \_\_\_\_\_ **NL** Neo-Loc
- \_\_\_\_\_ **NL** Neo-Loc

**PIPE SIZE** (Specify size)

- \_\_\_\_\_ 2" thru 6", 8", 10"
- \_\_\_\_\_ 2" thru 6"
- \_\_\_\_\_ 2" thru 6", 8", 10"
- \_\_\_\_\_ 2" thru 6", 8", 10"
- \_\_\_\_\_ 2" thru 4"
- \_\_\_\_\_ 5", 6"

**'E' BODY HT. DIMENSION**

- \_\_\_\_\_ 5-1/4"
- \_\_\_\_\_ 5-1/4"
- \_\_\_\_\_ 3-3/4"
- \_\_\_\_\_ 5-1/4"
- \_\_\_\_\_ 4-5/8"
- \_\_\_\_\_ 5-1/2"

**PREFIXES**

- \_\_\_\_\_ **Z-** D.C.C.I. Body and Grate\*
- \_\_\_\_\_ **ZB-** D.C.C.I. Body with Polished Bronze Top (Add 3/16" to 1-3/4" Dim.)
- \_\_\_\_\_ **ZN-** D.C.C.I. Body with Polished Nickel Bronze Top (Add 3/16" to 1-3/4" Dim.)

**SUFFIXES**

- \_\_\_\_\_ **-C** Underdeck Clamp
- \_\_\_\_\_ **-G** Galvanized Cast Iron
- \_\_\_\_\_ **-DG** Duresist Grate
- \_\_\_\_\_ **-VP** Vandal Proof Secured Top
- \_\_\_\_\_ **-XJ** Vertical Expansion Joint (See Z-190)  
(Use with IP Type Outlets)

<b>REV.</b>	<b>DATE: 1/12/94</b>	<b>C.N. NO. 69482</b>
<b>DWG. NO. P-13909 PRODUCT NO. Z-534-83</b>		

\*REGULARLY FURNISHED UNLESS OTHERWISE SPECIFIED