



Z-516-77

12" [305] DIAMETER EXTRA HEAVY DUTY DRAIN

TAG _____

Dimensional Data (inches and [mm]) are Subject to Manufacturing Tolerances and Change Without Notice

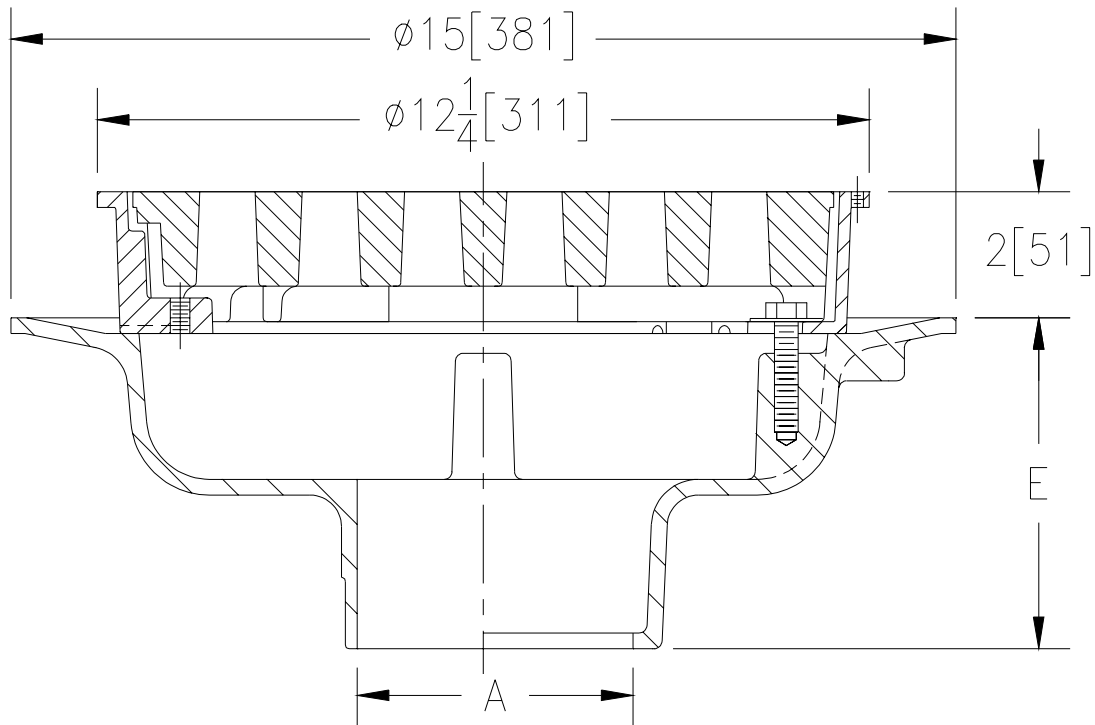

A- Pipe Size In.	Approx. Wt. Lbs. [kg]	Grate Open Area Sq. In. [cm ²]
2-3-4-5-6 [50-75-100-125-150]	45 [20]	30 [194]
8-10 [200-250]	47 [21]	

ENGINEERING SPECIFICATION: ZURN Z-516-77 12 [305] Diameter top drain. Dura-Coated cast iron body with bottom outlet, seepage pan and combination membrane flashing clamp and frame for extra heavy duty deep flange slotted grate.

OPTIONS (Check/specify appropriate options)

PIPE SIZE

(Specify size/type) **OUTLET**

'E' BODY HT. DIM.

2 thru 6, 8, 10 [50 thru 150, 200, 250]	_____ IC Inside Caulk	5 1/4 [133]
2 thru 6, 8 [50 thru 150, 200]	_____ IG Inside Caulk w/Sealtrol Gskt.	5 1/4 [133]
2 thru 6, 8, 10 [50 thru 150, 200, 250]	_____ IP Threaded	3 3/4 [95]
2 thru 6, 8, 10 [50 thru 150, 200, 250]	_____ NH No-Hub	5 1/4 [133]
2 thru 4 [50 thru 100]	_____ NL Neo-Loc	4 5/8 [117]

PREFIXES

_____ Z- D.C.C.I. Body and Grate*

SUFFIXES

- _____ -DG Duresist Grate
- _____ -G Galvanized Cast Iron
- _____ -S Secondary Strainer
- _____ -V Backwater Valve (See Z-1099)
- _____ -VP Vandal Proof Secured Top

REV.	DATE: 10/15/96	C.N. NO. 76206
DWG. NO. P-14405 PRODUCT NO. Z-516-77		

*REGULARLY FURNISHED UNLESS OTHERWISE SPECIFIED