



ZS880-SO
STAINLESS STEEL
LINEAR SHOWER DRAIN W/ SIDE OUTLET

SPECIFICATION SHEET

TAG _____

Dimensional data (inches and [mm]) are subject to manufacturing tolerances and change without notice.

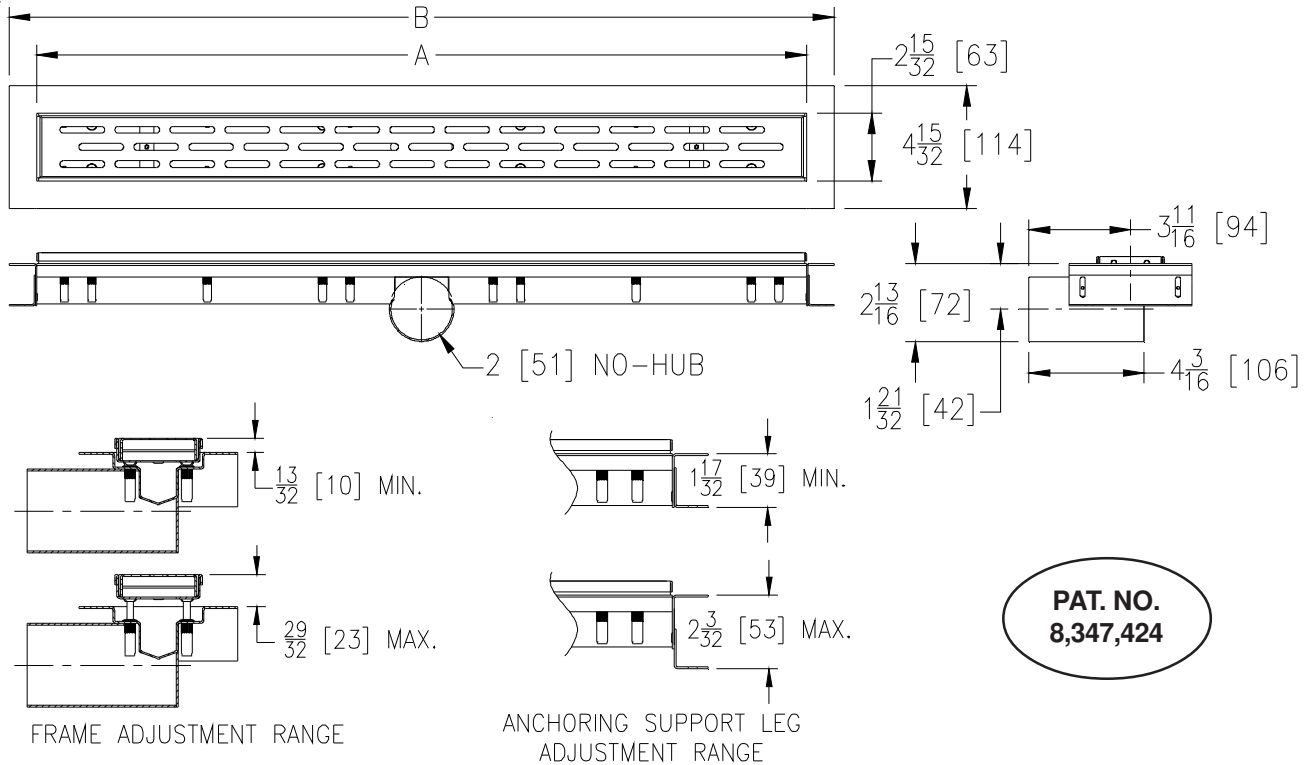

PAT. NO.
8,347,424

Dimensions In Inches [mm]			Approx. Wt. Lbs. [kg]	Grate Open Area Sq. In. [cm ²]
Product Designation	A	B		
-12	12 [305]	14 [356]	2.9 [1.3]	6 [38]
-28	28 [711]	30 [762]	5.4 [2.5]	15 [97]
-32	32 [813]	34 [864]	5.9 [2.7]	18 [116]
-36	36 [914]	38 [965]	6.4 [2.9]	20 [129]
-40	40 [1016]	42 [1069]	7.2 [3.3]	22 [142]
-48	48 [1219]	50 [1270]	8.4 [3.8]	27 [174]
-60	60 [1524]	62 [1575]	10.3 [4.7]	34 [219]
-72	72 [1829]	74 [1880]	12.4 [5.6]	41 [265]

ENGINEERING SPECIFICATION: ZS880-SO

All Type 304 (CF8) Fabricated Stainless Steel Linear Shower Drain. Complete with vertically adjustable anchoring support legs, anti-ponding V-shaped channel with 2" [51 mm] No-Hub side outlet, adjustable secured leveling frame with built-in tile edge, and secured, light-duty, slotted heel-proof grate. Drain can be adjusted to accommodate 1/4" [6mm] and 3/8" [10mm] finished tile thicknesses.

OPTIONS (Check/specify appropriate options)

PREFIXES

- ___ ZS All Type 304 (CF8) Stainless Steel*
- ___ ZR All Type 304 (CF8) Stainless Steel w/ Oil-Rubbed Bronze Finish

GRATE OPTIONS

- ___ -BW Basket Weave Grate
- ___ -DB Decorative Block Grate
- ___ -SG Serenity Grate
- ___ -TG Tile In-Lay Grate
- ___ -WG Wave Grate

SUFFIXES

- ___ -EO End Side Outlet (2 [51] No-Hub, Not Available on Size -12)
- ___ -FS Outlet Filter Screen
- ___ -2 Two Side Outlets (2 [51] No-Hub, Not Available on Size -12)
- ___ -3 Three Side Outlets (2 [51] No-Hub, Not Available on Size -12)

* Regularly furnished unless otherwise specified