



# Z520-86

## 9 [229] ADJUSTABLE HEAVY-DUTY DRAIN W/ STABILIZER ASSEMBLY

SPECIFICATION SHEET

TAG \_\_\_\_\_

Dimensional Data (inches and [ mm ]) are Subject to Manufacturing Tolerances and Change Without Notice

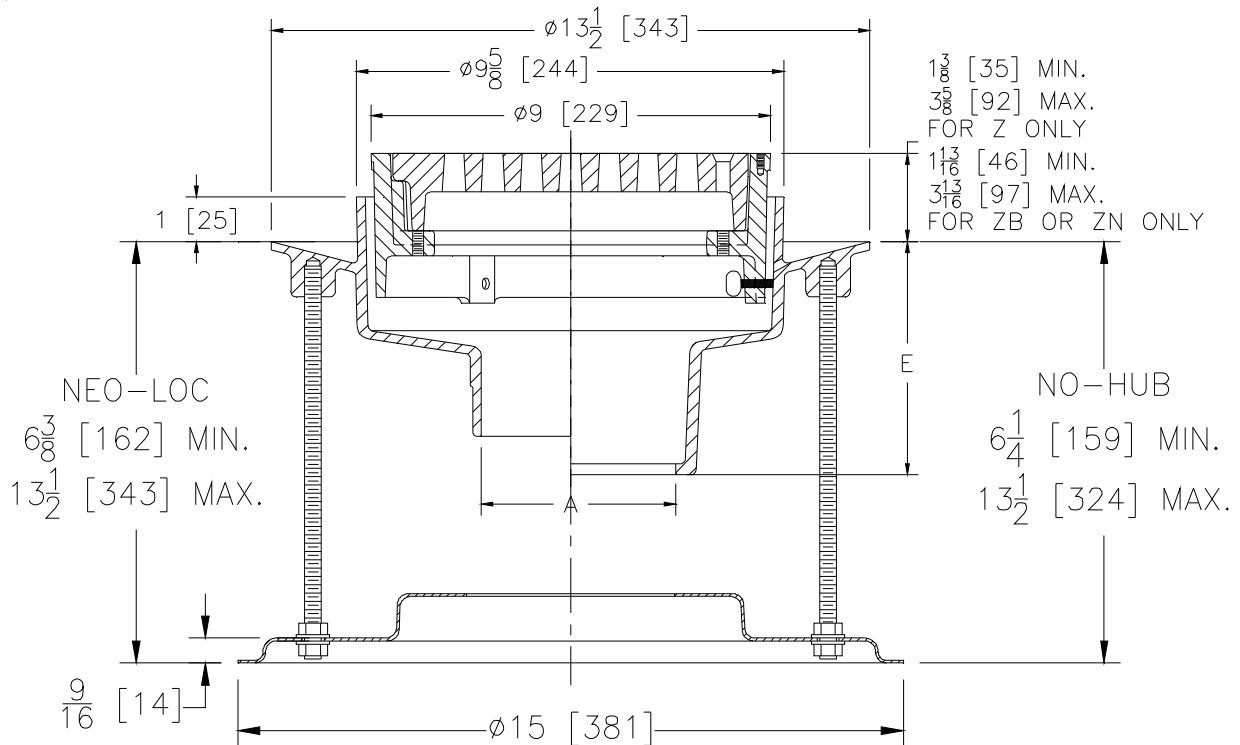

| A<br>Pipe Size In. | Approx.<br>Wt. Lbs.<br>[kg] | Grate Open Area<br>Sq. In. [cm <sup>2</sup> ] |
|--------------------|-----------------------------|---|
| 2-3-4 [51-76-102]  | 44 [20]                     | 18 [116]                                      |

**ENGINEERING SPECIFICATION: ZURN Z520-86**  
9 [229] Diameter top drain, Dura-Coated cast iron body with bottom outlet, seepage pan and adjustable extension frame with heavy-duty cast iron deep flange slotted grate and stabilizer assembly.

### OPTIONS (Check/specify appropriate options)

#### PIPE SIZE

2 thru 4 [51 thru 102]  
2 thru 4 [51 thru 102]

(Specify size/type) **OUTLET**

\_\_\_ NH No-Hub  
\_\_\_ NL Neo-Loc

**'E' DIM.**

4-1/4 [108]  
4-3/8 [111]

#### PREFIXES

\_\_\_ Z D.C.C.I. Body and Top\*  
\_\_\_ ZB D.C.C.I. Body w/ Polished Bronze Top (Add 5/8 [16] to 9 [229] Dim.)  
\_\_\_ ZN D.C.C.I. Body w/ Polished Nickel Bronze Top (Add 5/8 [16] to 9 [229] Dim.)

#### SUFFIXES

\_\_\_ -AR Acid Resisting Epoxy Coated Cast Iron  
\_\_\_ -DG Duresist Grate  
\_\_\_ -F Extension Frame (Specify Total Height Req'd)  
\_\_\_ -G Galvanized Cast Iron  
\_\_\_ -HP Heel-Proof Grate  
\_\_\_ -P Trap Primer Connection  
\_\_\_ -S Secondary Strainer  
\_\_\_ -SC Solid Cover  
\_\_\_ -SG Solid Gasketed Cover  
\_\_\_ -SS Stainless Mesh Liner for Bucket  
\_\_\_ -T Square Top  
\_\_\_ -TC Neo-Loc Test Cap Gasket (2-4 [51-102] NL Bottom Outlet Only)  
\_\_\_ -TS Top Secured with Slotted Screws  
\_\_\_ -V Backwater Valve (See Z1099)  
\_\_\_ -VP Vandal-Proof Secured Top  
\_\_\_ -Y Sediment Bucket

\*REGULARLY FURNISHED UNLESS OTHERWISE SPECIFIED

REV. DATE: 04/27/12 C.N. NO. 124193

DWG. NO. 309593

PRODUCT NO. Z520-86

ZURN INDUSTRIES, LLC ♦ SPECIFICATION DRAINAGE OPERATION ♦ 1801 Pittsburgh Ave. ♦ Erie, PA 16514

Phone: 814/455-0921 ♦ Fax: 814/454-7929 ♦ World Wide Web: www.zurn.com

In Canada: ZURN INDUSTRIES LIMITED ♦ 3544 Nashua Drive ♦ Mississauga, Ontario L4V1L2 ♦ Phone: 905/405-8272 Fax: 905/405-1292