



# Z100-198

15 [381] DIAMETER MAIN ROOF DRAIN W/ FLOW CONTROLLING WATER DAM AND STAINLESS STEEL PERFORATED GRAVEL GUARD

SPECIFICATION SHEET

TAG \_\_\_\_\_

Dimensional Data (inches and [ mm ]) are Subject to Manufacturing Tolerances and Change Without Notice

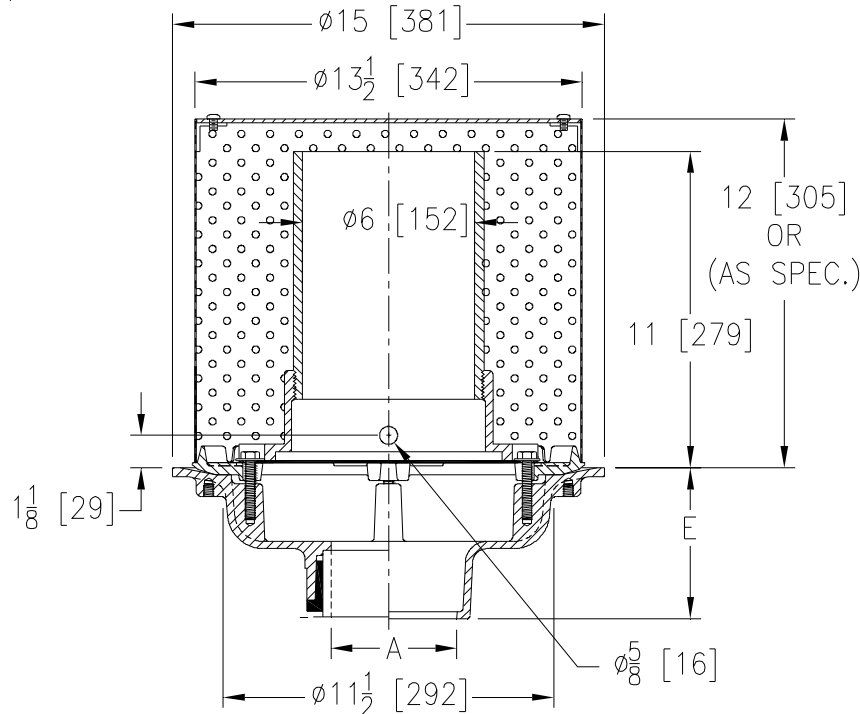

A Pipe Size In. [mm]	Approx. Wt. Lbs. [kg]
2,3,4 [51,76,102]	36 [16]
5,6 [127,152]	37 [17]
8 [203]	38 [18]

**ENGINEERING SPECIFICATION: ZURNZ100-198**

15" [381mm] Diameter roof drain. Dura-Coated cast iron body with combination membrane flashing clamp/gravel guard, gasketed flow control water dam with 5/8" [16mm] dia hole, 6" [152mm] standpipe and stainless steel perforated gravel guard with solid secured top.

**OPTIONS** (Check/specify appropriate options)

**PIPE SIZE**

- 2,3,4,5,6,8 [51,76,102,127,152,203]
- 2,3,4,5,6,8 [51,76,102,127,152,203]
- 2,3,4,5,6,8 [51,76,102,127,152,203]
- 2,3,4 [51,76,102]
- 6 [152]

(Specify size/type) **OUTLET**

- \_\_\_ IC Inside Caulk
- \_\_\_ IP Threaded
- \_\_\_ NH No-Hub
- \_\_\_ NL Neo-Loc
- \_\_\_ NL Neo-Loc

**E BODY HT. DIM.**

- 5-1/4 [133]
- 3-3/4 [95]
- 5-1/4 [133]
- 4-9/16 [116]
- 5-7/16 [112]

**PREFIXES**

- \_\_\_ Z D.C.C.I. Body

**SUFFIXES**

- \_\_\_ -AC Angular Underdeck Clamp
- \_\_\_ -AR Acid Resistant Epoxy Coated
- \_\_\_ -C Underdeck Clamp
- \_\_\_ -DE Deck Extension
- \_\_\_ -DP Top-Set® Deck Plate (Replaces both the -C and -R)
- \_\_\_ -DR Top-Set® Drain Riser
- \_\_\_ -DX Dex-o-tex Flange
- \_\_\_ -E Static Extension 1 [25] thru 4 [102] (Specify Ht.)
- \_\_\_ -EA Adjustable Extension Assembly (2-1/8 [54] thru 3-1/2 [89])
- \_\_\_ -EB Top-Set® Adjustable Extension Assembly
- \_\_\_ -G Galvanized Cast Iron
- \_\_\_ -R Roof Sump Receiver
- \_\_\_ -SC Secondary Clamp Collar
- \_\_\_ -TC Neo-Loc Test cap basket (2,3,4 [51,76,102]) NL Bottom Outlet Only)
- \_\_\_ -VP Vandal-Proof Secured Top
- \_\_\_ -90 90° Threaded Side Outlet Body (2 thru 6 [51 or 152])

\* Regularly furnished unless otherwise specified.

Zurn Industries, LLC | Specification Drainage Operation  
 1801 Pittsburgh Avenue, Erie, PA U.S.A. 16502 · Ph. 855-663-9876, Fax 814-454-7929  
 In Canada | Zurn Industries Limited  
 3544 Nashua Drive, Mississauga, Ontario L4V 1L2 · Ph. 905-405-8272, Fax 905-405-1292  
[www.zurn.com](http://www.zurn.com)

Rev. A  
 Date: 05/05/15  
 C.N. No. 132622  
 Prod. | Dwg. No. Z100-198