



Z1170-166

ADJUSTABLE RECESSING RECEIVER FOR GREASE INTERCEPTOR WITH FLOW CONTROL FITTING AND INTEGRAL EXTENSION

SPECIFICATION SHEET

TAG _____

Dimensional Data (inches and [mm]) are Subject to Manufacturing Tolerances and Change Without Notice

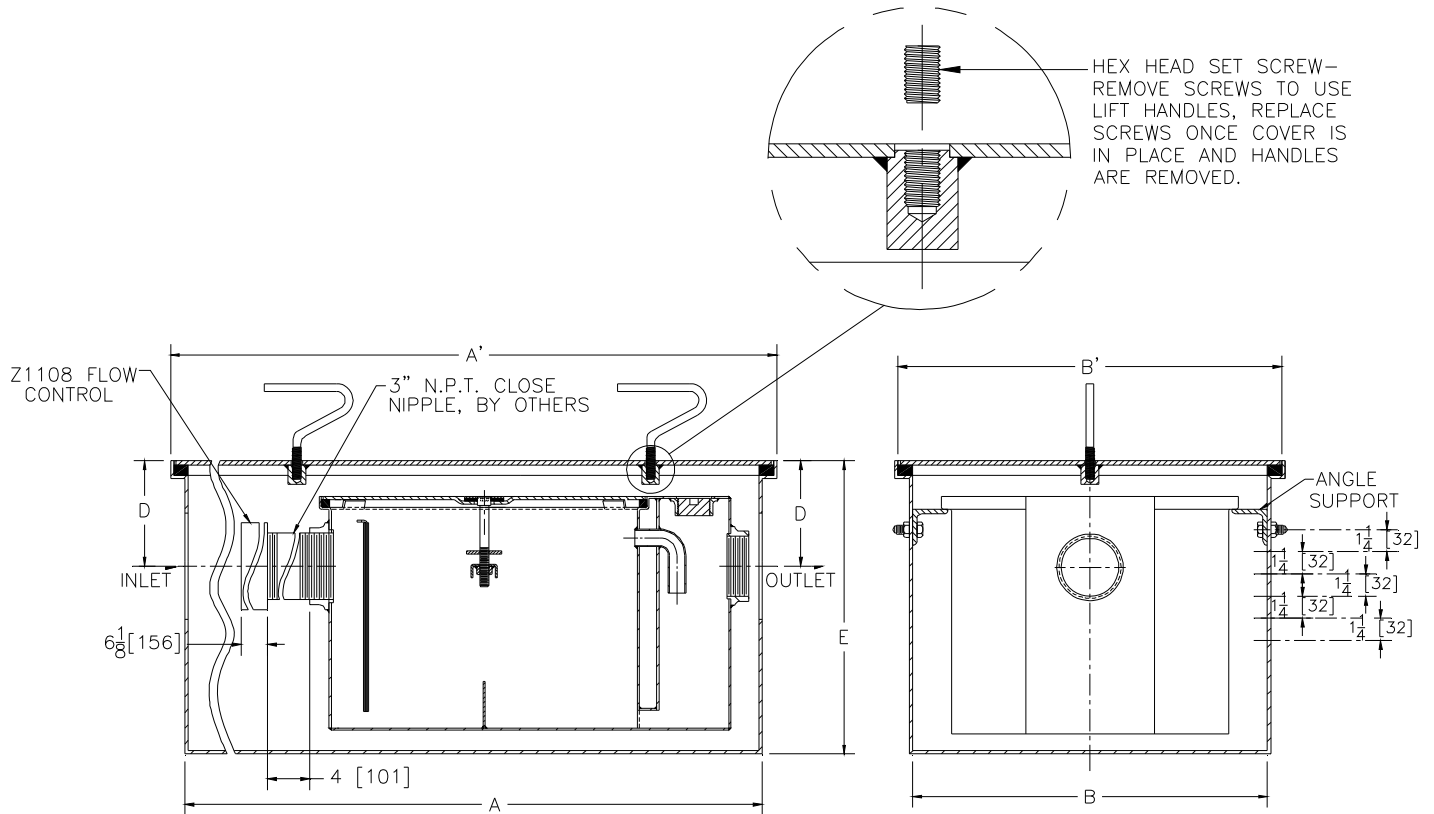

Size	Dimensions in Inches [mm]					
	A	A'	B	B'	D	E
500	47-1/4 [1200]	49-1/4 [1251]	20-3/4 [527]	22-5/8 [575]	9-1/2 [241]	32-1/2 [826]
800	53-1/4 [1353]	55-1/4 [1403]	28 [711]	29-7/8 [759]		

ENGINEERING SPECIFICATION: ZURN Z1170-166

Acid Resistant Epoxy Coated Recessing receiver equipped with adjustable support brackets and gasketed non-skid cover with removable lift handles. Complete with Z1170 Grease interceptor and Z1108 flow control fitting. For grease interceptor specifications see Z1170 specification sheet.

PREFIXES

___ Z Acid Resistant Coated Fabricated Steel*

SUFFIXES

- ___ -K Anchor flange 1-3/4 [44] down from top and 2 [51] wide. A 3 [76] minimum extension height is required when anchor flange (-K) option is specified.
- ___ -KC Anchor flange 1-3/4 [44] down from top and 2 [51] wide with clamp collar. A 3 [76] minimum extension height is required when anchor flange (-KC) option is specified.

* Regularly furnished unless otherwise specified.