



Z-352-75 SMALL PLANTING AREA DRAIN

SPECIFICATION SHEET

TAG _____

Dimensional Data (inches and [mm]) are Subject to Manufacturing Tolerances and Change Without Notice

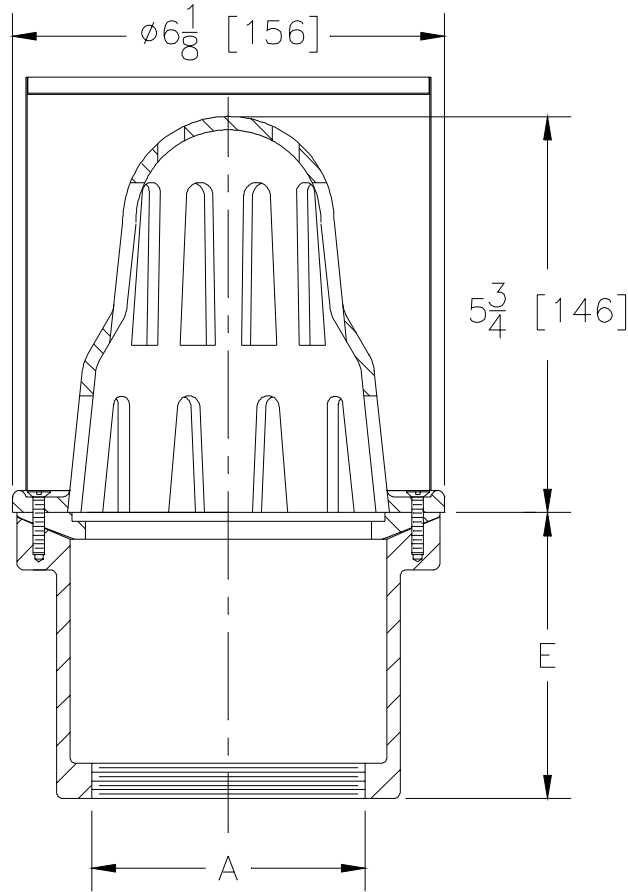

A-Pipe Size Inches	Approx. Wt. Lbs.	Dome Open Area Sq. In.
3 [75]	5 [2]	20 [129]
4 [100]	7 [3]	20 [129]

ENGINEERING SPECIFICATION: ZURN ZRB-352-75 6" [152] Diameter Small Area Planting Drain, Dura-Coated cast iron body with bottom outlet, plain bronze membrane flashing clamp and high dome strainer with stainless steel mesh screen over dome.

OPTIONS (Check/specify appropriate options)

OUTLET

____ IP Threaded

PIPE SIZE (Specify size)

____ 3", 4" [75, 100]

**'E' BODY HT.
DIMENSION**

4" [100]

PREFIXES

____ **ZRB-** D.C.C.I. Body with Bronze Dome and Stainless Steel Mesh Screen*

SUFFIXES

- ____ **-G** Galvanized Cast Iron
- ____ **-VP** Vandal Proof Secured Top
- ____ **-45** 45° Outlet
- ____ **-90** 90° Side Outlet

REV. _____	DATE: <u>3/5/93</u>	C.N. <u>68934</u>
DWG. NO. <u>P-13803</u>	PRODUCT <u>Z-352-75</u>	NO. _____

*REGULARLY FURNISHED UNLESS OTHERWISE SPECIFIED