

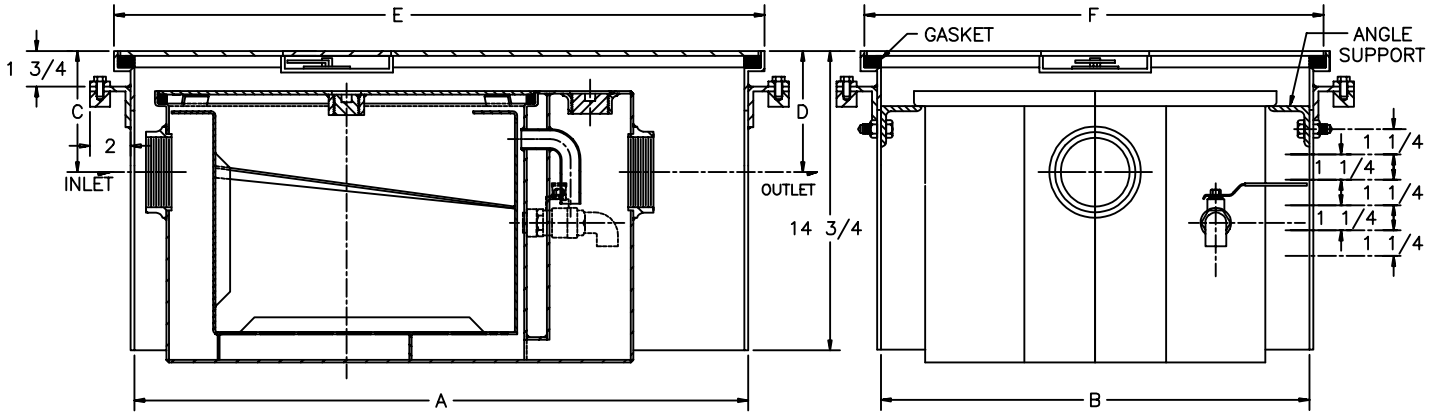

Z-1173-KC-R
ADJUSTABLE RECESSING
RECEIVER FOR GREASEPTOR

TAG _____

Dimensions Subject to Manufacturing Tolerances



Size	Dimensions In Inches					
	A	B	C	D	E	F
400	29-1/2	17-1/2	4-7/8	4-7/8	31-1/2	19-1/2
500	31-5/8	20	5-3/8	5-3/8	33-5/8	22
600	34-1/4	20-3/4	5-3/4	5-3/4	36-1/4	22-3/4
700	39-1/2	23-1/4	5-7/8	5-7/8	41-1/2	25-1/4
800	40	26	5-7/8	5-7/8	42	28
900	42-3/4	28	6-7/8 ⁺	6-7/8 ⁺	44-3/4	30

ENGINEERING SPECIFICATION: ZURN Z-1173-KC-R
 Acid Resistant Epoxy Coated Recessing receiver equipped with adjustable support brackets, anchor flange 2" wide with clamp collar and gasketed non-skid cover with recessed and covered lift handle. Complete with Z-1173 Greaseptor for greaseptor specifications see Z-1173 drawing.

PREFIXES

— **Z-** Acid Resistant Coated Fabricated Steel*

SUFFIXES

- **-K** Anchor flange 1-3/4" down from top and 2" wide. A 3" minimum extension height is required when anchor flange (-K) option is specified. (Specify 'C' Dim. height required)
- **-T** Cover recessed for tile/terrazzo. A 3" minimum extension height is required. (Specify 'C' Dim. and required recess depth - 1/8", 3/4", or 1-1/4").
- +** Subtract 3/4" when 2" Inlet and Outlet is Specified.

*REGULARLY FURNISHED UNLESS OTHERWISE SPECIFIED

REV.	DATE: 8/9/94	C.N. NO. 69942
DWG. NO. 58370	PRODUCT NO. Z-1173-KC-R	