



Z100-352

15 [381] DIAMETER MAIN ROOF DRAIN WITH STANDPIPE AND 13/16 [21] ORIFICE

SPECIFICATION SHEET

TAG _____

Dimensional Data (inches and [mm]) are Subject to Manufacturing Tolerances and Change Without Notice

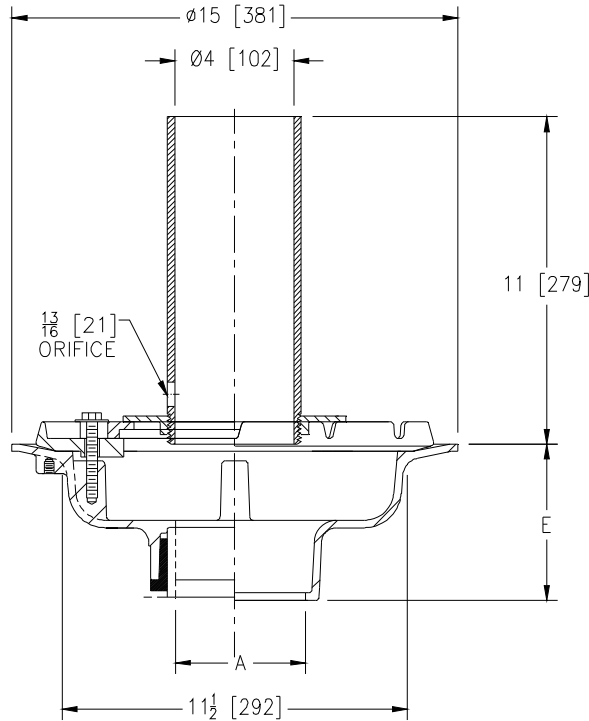

A Pipe Size In. [mm]	Approx. Wt. Lbs. [kg]
2,3,4 [51,76,102]	36 [16]
6 [152]	37 [17]
8 [203]	38 [18]

ENGINEERING SPECIFICATION: ZURNZ100-352

15" [381mm] Diameter roof drain. Dura-Coated cast iron body with combination membrane flashing clamp/gravel guard, 4" [102mm] standpipe with 13/16" [21mm] orifice.

OPTIONS (Check/specify appropriate options)

PIPE SIZE

- 3, 4, 6 [72,102,152]
- 2, 3, 4, 6, 8 [51,72,102,152,203]
- 2, 3, 4, 6, 8 [51,72,102,152,203]
- 2,3,4 [51,76,102]
- 6 [152]

(Specify size/type) **OUTLET**

- ___ IC Inside Caulk
- ___ IP Threaded
- ___ NH No-Hub
- ___ NL Neo-Loc
- ___ NL Neo-Loc

'E' BODY HT. DIM.

- 5-1/4 [133]
- 3-3/4 [95]
- 5-1/4 [133]
- 4-9/16 [116]
- 5-7/16 [112]

PREFIXES

- ___ Z D.C.C.I. Body*

SUFFIXES

- | | |
|---|---|
| ___ -AC Angular Underdeck Clamp | ___ -FG Flush Grate |
| ___ -AR Acid Resistant Epoxy Coated | ___ -G Galvanized Cast Iron |
| ___ -AW 3/4 [19] to 4 [102] Adj. Water Level Regulator (Specify Height) (ZC Only) | ___ -R Roof Sump Receiver |
| ___ -C Underdeck Clamp | ___ -SC Secondary Clamp Collar |
| ___ -DE Deck Extension | ___ -TC Neo-Loc Test Cap Gasket (2, 3, 4 [51, 76, 102] NL Bottom Outlet Only) |
| ___ -DP Top-Set® Deck Plate (Replaces both the -C and -R) | ___ -VP Vandal-Proof Secured Top |
| ___ -DR Top-Set® Drain Riser | ___ -W2 2 [51] Internal Water Dam |
| ___ -E Static Extension 1 [25] thru 4 [102] (Specify Ht.) | ___ -W3 3 [76] Internal Water Dam |
| ___ -EA Adjustable Extension Assembly | ___ -W4 4 [102] Internal Water Dam |
| ___ -EB Top-Set® Adjustable Extension Assembly | ___ -84 Stainless Steel Perforated Gravel Guard |
| | ___ -89 2 [51] High External Water Dam |
| | ___ -90 90° Threaded Side Outlet Body |

* Regularly furnished unless otherwise specified.