



Z356-76

SPECIFICATION SHEET

FLOOR DRAIN WITH TRAP MULTI-INLETS, Ø4 [102] NO-HUB OUTLET W/ 6 [152] SQ. N.B. ADJUSTABLE TOP TAG _____

Dimensional Data (inches and [mm]) are Subject to Manufacturing Tolerances and Change Without Notice

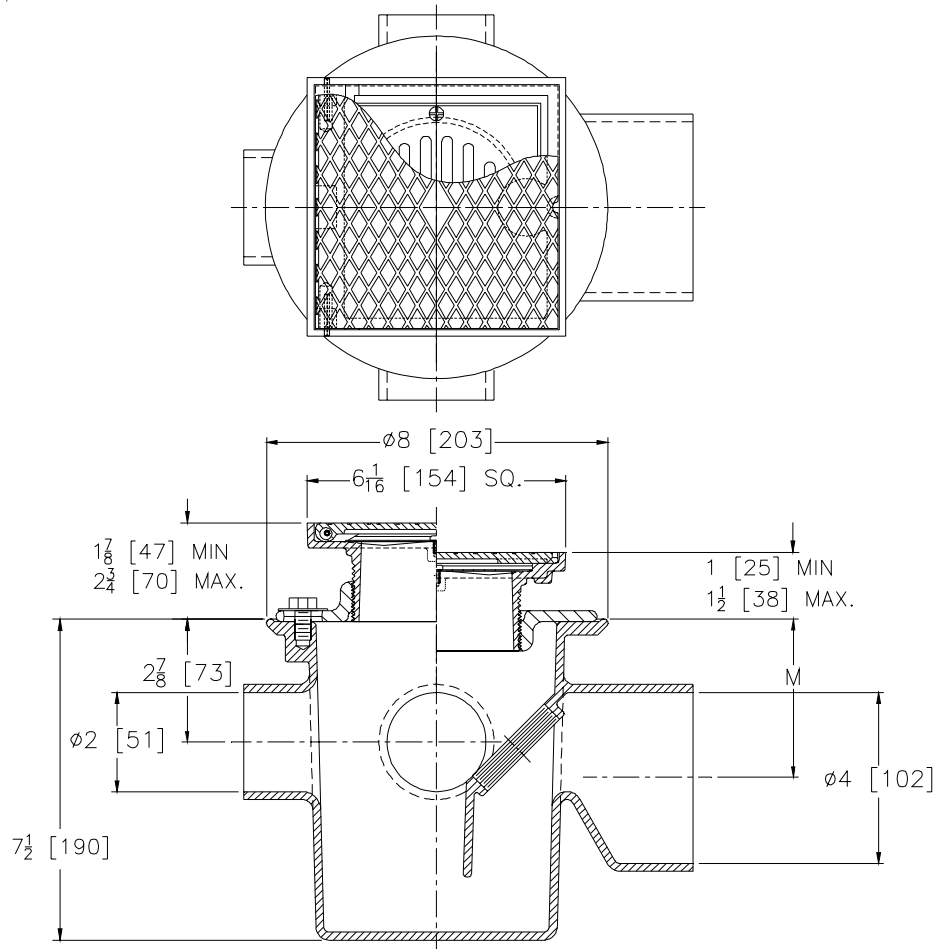

Dimensions In Inches		Approx. Wt. Lbs. [kg]
A-Pipe Size	M	
4 [102]	3 23/32 [94]	18 [8]

ENGINEERING SPECIFICATION: ZURN ZN356 Multi-Inlet adjustable floor drain with trap, 4 [102] No-Hub outlet, Dura-Coated cast iron body with integral trap seal, complete with plastic cleanout plug, inverta collar, 6 [152] square, polished nickel bronze adjustable top with solid scoriated hinged cover, and three 2 [51] No-Hub auxiliary inlet connections.

OPTIONS (Check/specify appropriate options)

PIPE SIZE

4 [102]

(Specify size/type) **OUTLET**

____ NH No-Hub

'E' BODY HT. DIM.

7 1/2 [190]

PREFIXES

____ ZN D.C.C.I. Body w/ Polished Nickel Bronze Top*

SUFFIXES

- ____ -BP Bronze Plug
- ____ -G Galvanized Cast Iron
- ____ -VP Vandal-Proof Secured Top

*REGULARLY FURNISHED UNLESS OTHERWISE SPECIFIED

REV.	DATE: 05/04/10	C.N. NO. 111085
DWG. NO. 300292	PRODUCT NO. Z356-76	

ZURN INDUSTRIES, LLC. ♦ SPECIFICATION DRAINAGE OPERATION ♦ 1801 Pittsburgh Ave. ♦ Erie, PA 16514

Phone: 814/455-0921 ♦ Fax: 814/454-7929 ♦ World Wide Web: www.zurn.com

In Canada: ZURN INDUSTRIES LIMITED ♦ 3544 Nashua Drive ♦ Mississauga, Ontario L4V1L2 ♦ Phone: 905/405-8272 Fax: 905/405-1292