



Z503-81

15 [381] HEAVY-DUTY AREA DRAIN W/DOME GRATE AND SEDIMENT BUCKET

SPECIFICATION SHEET

TAG _____

Dimensional Data (inches and [mm]) are Subject to Manufacturing Tolerances and Change Without Notice

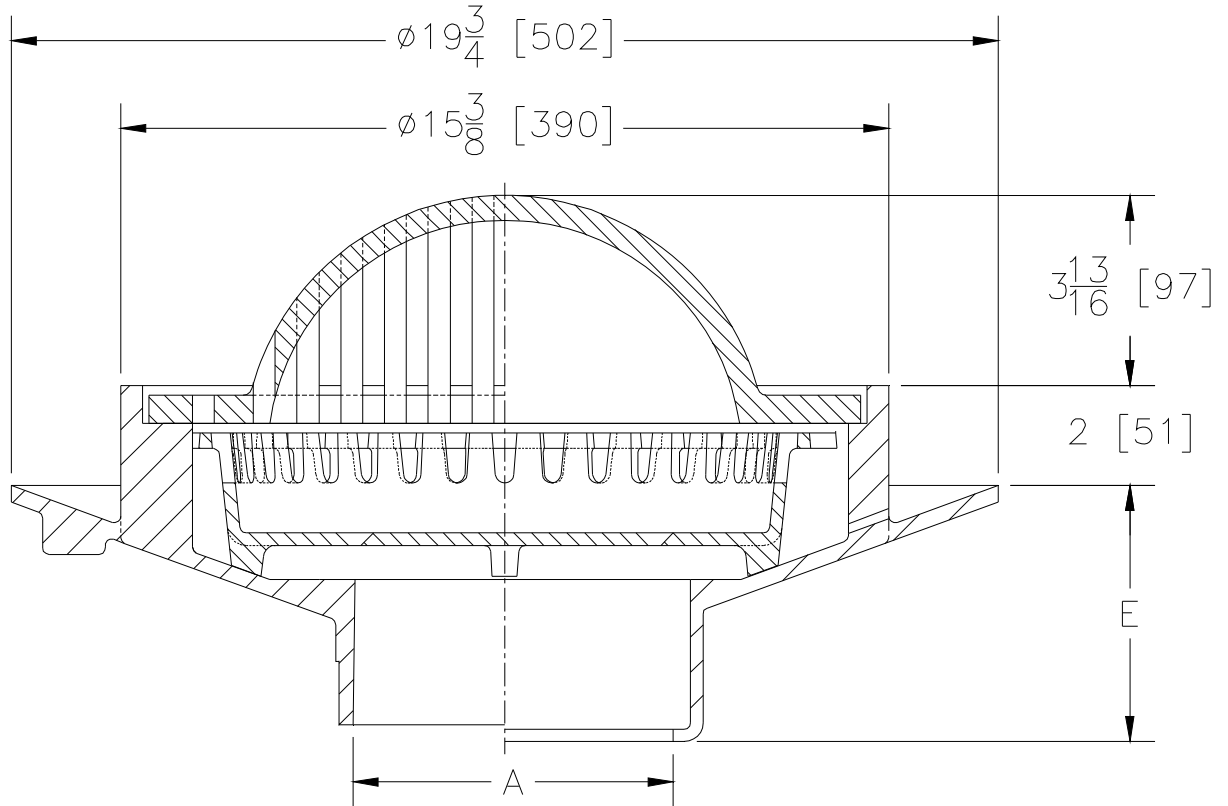

A Pipe Size In.	Approx. Wt. Lbs. [kg]	Grate Open Area Sq. In. [cm ²]
3-4-5-6-8 [76-102-127-152-203]	90 [41]	30 [194]

ENGINEERING SPECIFICATION: ZURN Z503-81

15 [381] Diameter top drain, Dura-Coated cast iron body with bottom outlet, seepage pan, dome grate, and sediment bucket.

OPTIONS (Check/specify appropriate options)

PIPE SIZE

- 3 thru 6 [76 thru 152]
- 8 [203]
- 3-4-6 [76-102-152]
- 3 thru 6-8 [76 thru 152-203]
- 4 [102]

(Specify size/type) **OUTLET**

- ___ IC Inside Caulk
- ___ IC Inside Caulk
- ___ IG Inside Caulk w/Sealtrol Gskt.
- ___ IP Threaded
- ___ NL Neo-Loc

'E' BODY HT. DIM.

- 5 1/8 [130]
- 5 5/8 [143]
- 5 1/8 [130]
- 3 [76]
- 3 7/8 [98]

PREFIXES

- ___ Z D.C.C.I. Body and Top*

SUFFIXES

- ___ -AR Acid Resisting Epoxy Coated Cast Iron
- ___ -C Clamp Collar
- ___ -G Galvanized Cast Iron
- ___ -TC Neo-Loc Test Cap Gasket
(4 [102] NL Bottom Outlet Only)
- ___ -V Backwater Valve (See Z1099)

REV.	DATE: 12/10/09	C.N. NO. 110508
DWG. NO. P-15807 PRODUCT NO. Z503-81		

*REGULARLY FURNISHED UNLESS OTHERWISE SPECIFIED

ZURN INDUSTRIES, LLC. ♦ SPECIFICATION DRAINAGE OPERATION ♦ 1801 Pittsburgh Ave. ♦ Erie, PA 16514

Phone: 814/455-0921 ♦ Fax: 814/454-7929 ♦ World Wide Web: www.zurn.com

In Canada: ZURN INDUSTRIES LIMITED ♦ 3544 Nashua Drive ♦ Mississauga, Ontario L4V1L2 ♦ Phone: 905/405-8272 Fax: 905/405-1292