



Z-1305-75

WALL HYDRANT

Encased, Non-Freeze

Dimensional Data (inches and [mm]) are Subject to Manufacturing Tolerances and Change Without Notice

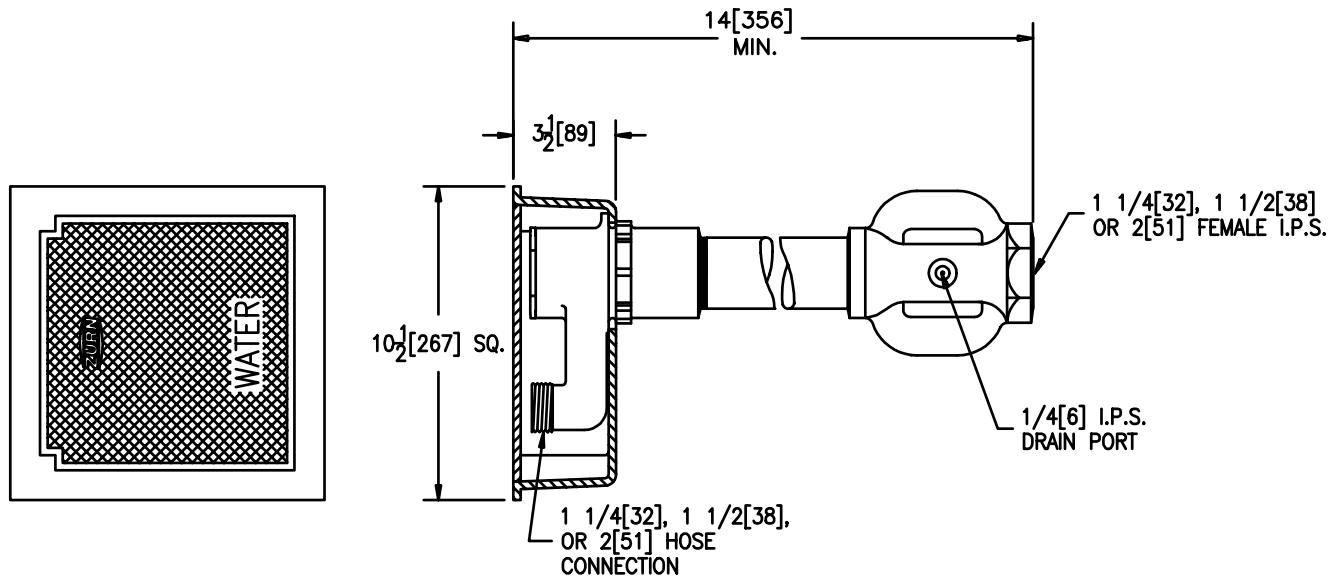
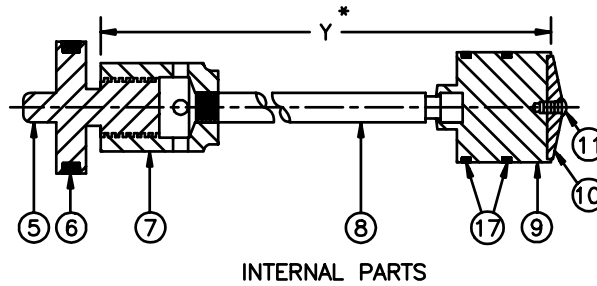

Depth of Bury Feet	Approx. Wt. Lbs. [kg]
2 [610]	42 [19]
3 [914]	
4 [1219]	
5 [1524]	
6 [1829]	
7 [2134]	
8 [2438]	

ENGINEERING SPECIFICATION: ZURN Z-1305-75 Encased, non-freeze, flush wall hydrant with bronze casing, all bronze interior parts, non-turning operating rod with free-floating compression closure valve with 1 1/4 [32], 1 1/2 [38] or 2 [51] connection. Dura-Coated cast iron box and hinged scoriated cover with operating "T" handle key lock and "WATER" cast on cover. Hydrant is equipped with a tapped 1/4 [6] drain port in valve housing.

Note:

- IMPORTANT Hydrant must be opened one turn to seal drain port during use.

PARTS LIST

Item	Name	Quan.
5	Operating Screw	1
6	O-Ring	1
7	Operating Coupling	1
8	Operating Rod	1
9	Washer Guide	1
10	Washer (neoprene)	1
11	Screw	1
17	O-Ring	2

OPTIONS (Check/specify appropriate options)

SUFFIXES

- ____ -RK Hydrant Parts Repair Kit
- ____ -6 Polished Bronze Box
- ____ -7 Plain Bronze Box
- ____ -10 Polished Nickel Bronze Box

REV.	DATE: 9/15/95	C.N. NO. 72798
DWG. NO. P-14242 PRODUCT NO. Z-1305-75		

*WHEN ORDERING REPLACEMENT PARTS SPECIFY Y DIM.