



Z100-256

SPECIFICATION SHEET

15 [381] DIAMETER MAIN ROOF DRAIN WITH 12 [305] EXTERNAL WATER DAM

TAG _____

Dimensional Data (inches and [mm]) are Subject to Manufacturing Tolerances and Change Without Notice

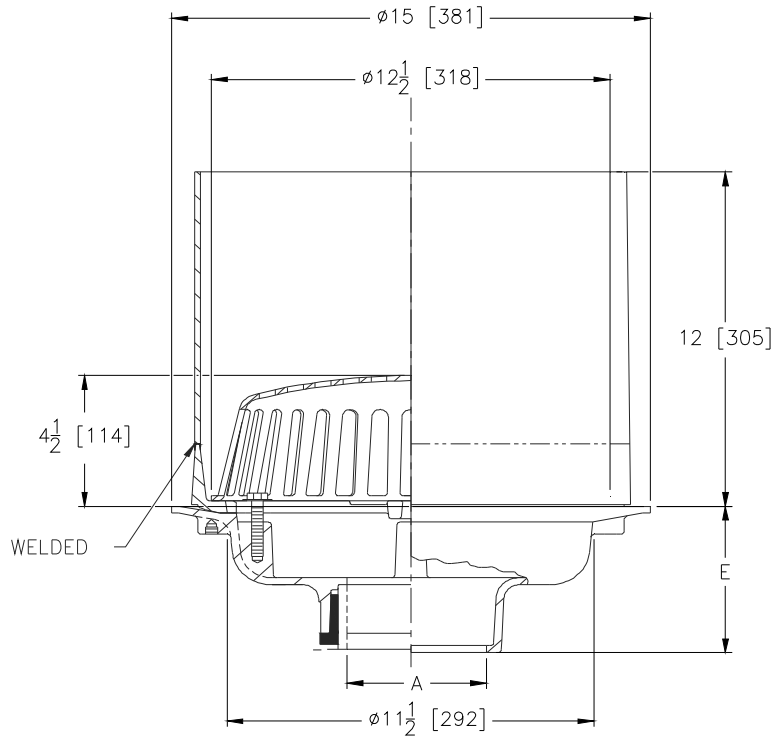

A- Pipe Size In.	Approx. Wt. Lbs. [kg]	Dome Open Area Sq. In. [cm ²]
2-3-4 [50-75-100]	53 [24]	103 [665]
5-6 [125-150]	54 [24]	
8 [200]	55 [25]	

ENGINEERING SPECIFICATION: ZURN Z100-256

15 [381] Diameter roof drain. Dura-Coated cast iron body with 12 [305] high combination membrane flashing clamp/gravel guard, and low silhouette Poly-Dome strainer.

OPTIONS (Check/specify appropriate options)

PIPE SIZE

2 thru 6, 8 [50 thru 150,200]
2 thru 6, 8 [50 thru 150,200]
2 thru 6, 8 [50 thru 150,200]
2,3,4 [50,75,100]

(Specify size/type) OUTLET

_____ IC Inside Caulk
_____ IP Threaded
_____ NH No-Hub
_____ NL Neo-Loc

E BODY HT. DIM.

5 1/4 [133]
3 3/4 [95]
5 1/4 [133]
4 5/8 [117]

PREFIXES

_____ Z D.C.C.I. Body with Poly-Dome*
_____ ZA- D.C.C.I. Body with 6 3/4 [171] High Aluminum Dome
_____ ZC- D.C.C.I. Body with Cast Iron Dome
_____ ZRB- D.C.C.I. Body with Plain Bronze Dome

SUFFIXES

_____ -AC Angular Underdeck Clamp	_____ -GD Galvanized Cast Iron Dome (ZC only)
_____ -AR Acid Resistant Epoxy Coated	_____ -HD 6 3/4 [171] High Aluminum Dome (148 sq. in. [955 cm ²] open area)
_____ -BS Bronze Mesh Screen Over Dome	_____ -R Roof Sump Receiver
_____ -C Underdeck Clamp	_____ -SS Stainless Steel Mesh Screen Over Dome
_____ -E Static Extension 1" [25] thru 4" [102] (Specify Ht.)	_____ -VP Vandal Proof Secured Top
_____ -EA Adjustable Extension Assembly 1 3/4 [44] thru 3 1/2 [89]	_____ -XJ Vertical Expansion Joint (See Z-190)
_____ -ES Static Extension with Secondary Clamp Collar at Body	_____ -90 90° Threaded Side Outlet Body
_____ -FG Flush Grate (Replaces Dome Strainer)	
_____ -G Galvanized Cast Iron	

REV. DATE: 01/04/13 C.N. NO. 128627

DWG. NO. 311170 PRODUCT NO. Z100-256

*REGULARLY FURNISHED UNLESS OTHERWISE SPECIFIED

ZURN INDUSTRIES, INC. ♦ SPECIFICATION DRAINAGE OPERATION ♦ 1801 Pittsburgh Ave. ♦ Erie, PA 16514

Phone: 814/455-0921 ♦ Fax: 814/454-7929 ♦ World Wide Web: www.zurn.com

In Canada: ZURN INDUSTRIES LIMITED ♦ 3544 Nashua Drive ♦ Mississauga, Ontario L4V1L2 ♦ Phone: 905/405-8272 Fax: 905/405-1292