



Z187-88
4 X 18 1/2 [102 X 470] SCUPPER DRAIN
W/ 45° BOTTOM OUTLET

SPECIFICATION SHEET

TAG _____

Dimensional Data (inches and [mm]) are Subject to Manufacturing Tolerances and Change Without Notice

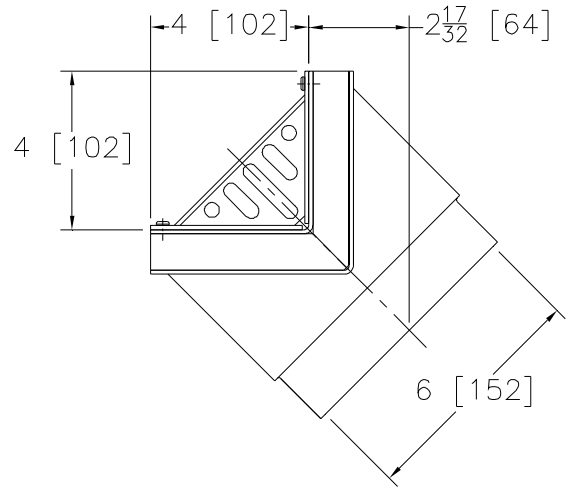
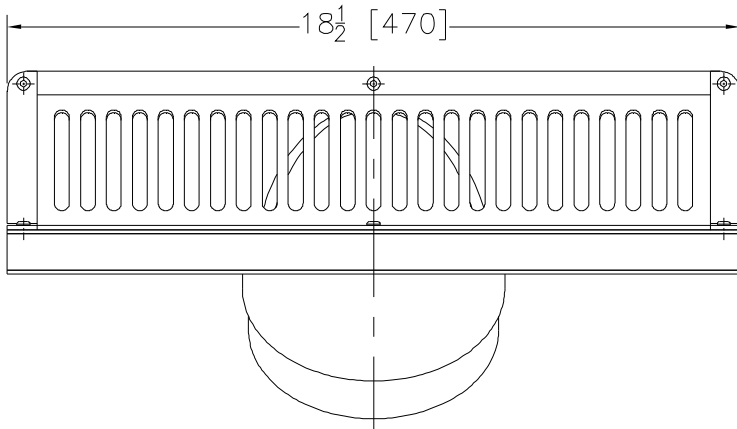

A-Pipe Size Inches	Approx. Wt. Lbs. [kg]	Grate Open Area Sq. In. [cm ²]
6 [152]	11 [5]	40 [258]

ENGINEERING SPECIFICATION: ZURN Z187-88

4 x 18 1/2 [102 x 470] Scupper drain, stainless steel body with 45° bottom outlet, and oblique vandal proof, secured stainless steel grate .

OPTIONS (Check/specify appropriate options)

PIPE SIZE

6 [150]

(Specify size/type) **OUTLET**

____ NH No-Hub

PREFIXES

____ ZS Stainless Steel Body with Grate*

SUFFIXES

- ____ -BS Bronze Mesh Screen Over Grate
- ____ -FG Flush Grate
- ____ -TS Secured Top With Slotted Screws

*REGULARLY FURNISHED UNLESS OTHERWISE SPECIFIED

REV. A	DATE: 04/07/08	C.N. NO. 98324
DWG. NO. P-14980	PRODUCT NO. Z187-88	