



# Z1204-N-A

## ADJUSTABLE VERTICAL SIPHON JET NO-HUB WITH Z1212 AUXILIARY SUPPORT ASSEMBLY

SPECIFICATION SHEET

TAG \_\_\_\_\_

Dimensions Subject to Manufacturing Tolerances

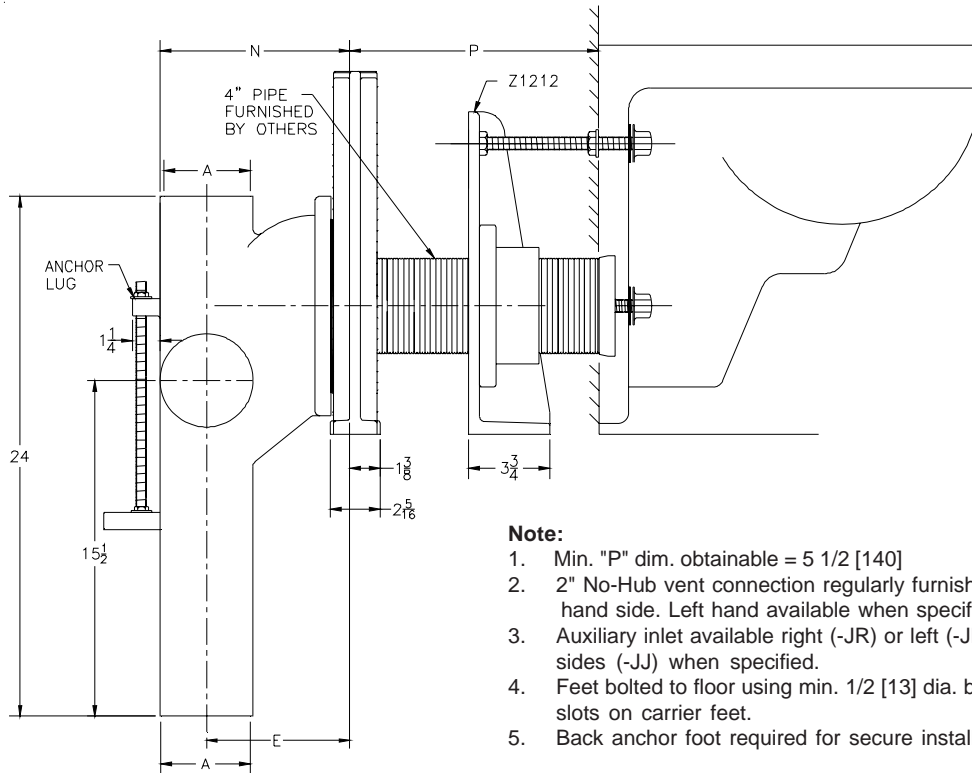

**Note:**

1. Min. "P" dim. obtainable = 5 1/2 [140]
2. 2" No-Hub vent connection regularly furnished on right hand side. Left hand available when specified (Suffix- VL)
3. Auxiliary inlet available right (-JR) or left (-JL) or both sides (-JJ) when specified.
4. Feet bolted to floor using min. 1/2 [13] dia. bolts and back slots on carrier feet.
5. Back anchor foot required for secure installation.

Product No.	Dimensions In Inches			Approx. Wt. Lbs. [kg]
	A	E	N	
Z1204-N4-N-A	4 [102]	6-5/8 [168]	9-3/4 [248]	110 [50]
Z1204-N5-N-A	5 [127]	6-5/8 [168]	10-1/8 [257]	115 [52]
Z1204-N6-N-A	6 [152]	7-1/8 [181]	10-1/8 [257]	125 [57]

**ENGINEERING SPECIFICATION: ZURN Z1204-N(-)A**

Adjustable, vertical siphon jet water closet "Rigid System" with ( ) size No-Hub connections and ( ) side inlets. Complete with Dura-Coated cast iron fitting, with 2" [102] vent, adjustable gasketed face plate, universal floor mounted foot supports, corrosion resistant adjustable ABS coupling with integral test cap, fixture bolts, trim, and stud protectors. Rear anchor tie down, and bonded "Neo-Seal" gasket. Furnished with Z1212 auxiliary support assembly.

**PRODUCT/DEFINITION**

\_\_\_\_\_ **Z1204-N(-)A** No-Hub Stack, Single Inlet, 2"[102] Right Hand Vent.

**PREFIXES**

- \_\_\_\_\_ **Z** D.C.C.I. System with Zurn "ZZ" Adjustable Coupling
- \_\_\_\_\_ **ZQ** D.C.C.I. System with NPT Face Plate, Non Adjustable Coupling
- \_\_\_\_\_ **ZC** D.C.C.I. System with Compression Fit Faceplate.
- \_\_\_\_\_ **ZF** D.C.C.I. System with Non-Adjustable, One-Piece Carrier

**SUFFIXES**

- |   |  |
|---|--|
| <ul style="list-style-type: none"> <li>_____ <b>-B</b> Blowout Type Fixture Support</li> <li>_____ <b>-BC</b> Back Cleanout</li> <li>_____ <b>-CC</b> Cast Iron Coupling 6"[152] Long</li> <li>_____ <b>-CL</b> Coupling Length Greater than 12"[305] (Specify length if greater than 6"[152])</li> <li>_____ <b>-G</b> Galvanized Cast Iron</li> <li>_____ <b>-JJ</b> Two 2"[102] Auxiliary Inlet</li> <li>_____ <b>-JL</b> 2"[102] Left Hand Auxiliary Inlet</li> <li>_____ <b>-JR</b> 2"[102] Right Hand Auxiliary Inlet</li> <li>_____ <b>-T</b> Threaded Stack Connection</li> <li>_____ <b>-VL</b> Left Hand Vent Connection</li> </ul> | <ul style="list-style-type: none"> <li>_____ <b>-VP</b> Vandal Proof Trim</li> <li>_____ <b>-29</b> Mechanical Test Cap Assembly (Previously Z1210-29)</li> <li>_____ <b>-45</b> Finishing Frame for Siphon Jet System (For Blowout System specify -45-B) (Previously Z1210-45)</li> <li>_____ <b>-50</b> Flush Valve Supply Support for WC.</li> <li>_____ <b>-61</b> "ZZ" Coupling Wrench</li> </ul> |
|---|--|

<b>REV. A</b>	<b>DATE: 02/17/10</b>	<b>C.N. NO. 110699</b>
<b>DWG. NO. 57305</b>	<b>PRODUCT NO. Z1204-N-A</b>	

\*REGULARLY FURNISHED UNLESS OTHERWISE SPECIFIED

ZURN INDUSTRIES, LLC. ♦ SPECIFICATION DRAINAGE OPERATION ♦ 1801 Pittsburgh Ave. ♦ Erie, PA 16514

Phone: 814/455-0921 ♦ Fax: 814/454-7929 ♦ World Wide Web: www.zurn.com

In Canada: ZURN INDUSTRIES LIMITED ♦ 3544 Nashua Drive ♦ Mississauga, Ontario L4V1L2 ♦ Phone: 905/405-8272 Fax: 905/405-1292