



Z1170-123

SPECIFICATION SHEET

GREASE INTERCEPTOR W/ ADJUSTABLE ENCLOSED RECESSING RECEIVER W/ INTEGRAL EXTENSION

TAG _____

Dimensional Data (inches and [mm]) are Subject to Manufacturing Tolerances and Change Without Notice

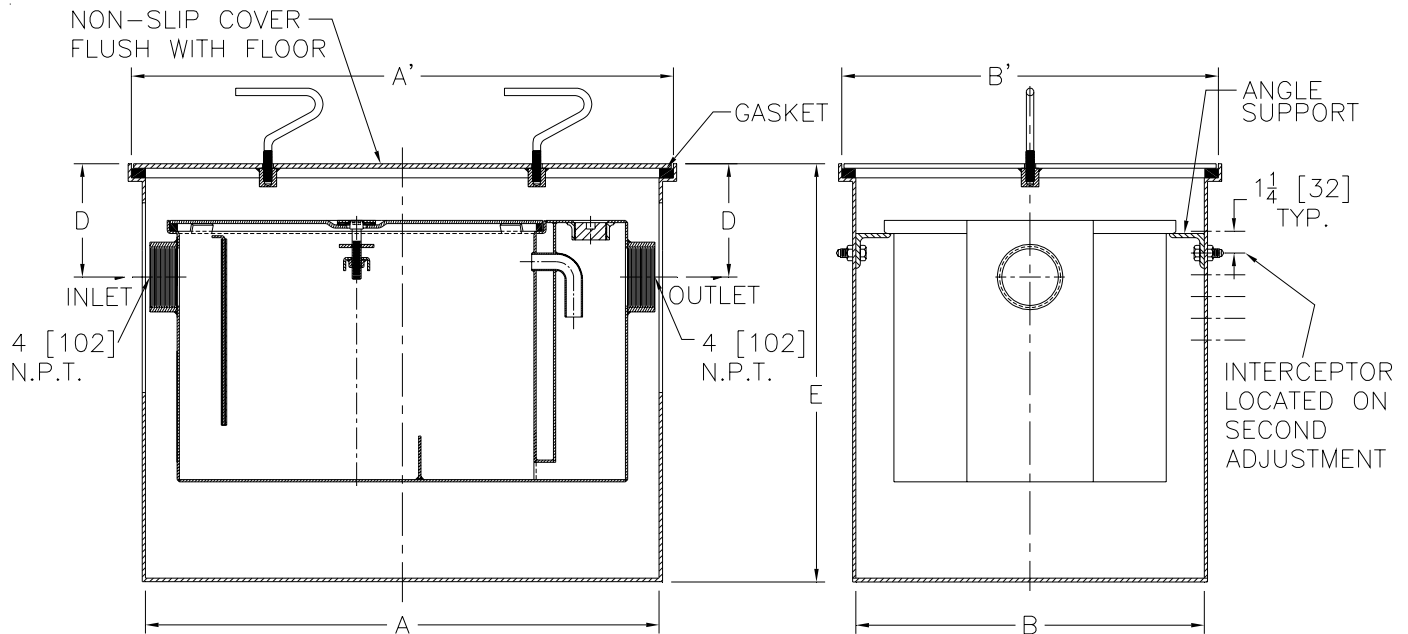

Size	Dimensions In Inches [mm]					
	A	A'	B	B'	D	E
800	37 1/4 [946]	39 1/4 [997]	28 [711]	30 [762]	26 [660]	47 3/4 [1213]

ENGINEERING SPECIFICATION:

ZURN Z1170-123 Acid Resistant Epoxy Coated Recessing receiver, enclosed type, equipped with integral extension, adjustable support brackets and gasketed non-skid cover with removable lift handles. Complete with Z1170 Grease Interceptor. For interceptor specifications see Z1170 specification sheet.

PREFIXES

_____ Z Acid Resistant Coated Fabricated Steel*

SUFFIXES

- _____ -K Anchor flange 1-3/4 [44] down from top and 2 [51] wide. A 3 [76] minimum extension height is required when anchor flange (-K) option is specified.
- _____ -KC Anchor flange 1-3/4 [44] down from top and 2 [51] wide with clamp collar. A 3 [76] minimum extension height is required when anchor flange (-KC) option is specified.
- _____ -T Cover recessed for tile/terrazzo. A 3 [76] minimum extension height is required. (Specify required recess depth - 1/8 [3], 3/4 [19], or 1-1/4 [32]).

REV.	DATE: 08/23/07	C.N. NO. 97200
DWG. NO. P-15467	PRODUCT NO. Z1170-123	

*REGULARLY FURNISHED UNLESS OTHERWISE SPECIFIED