

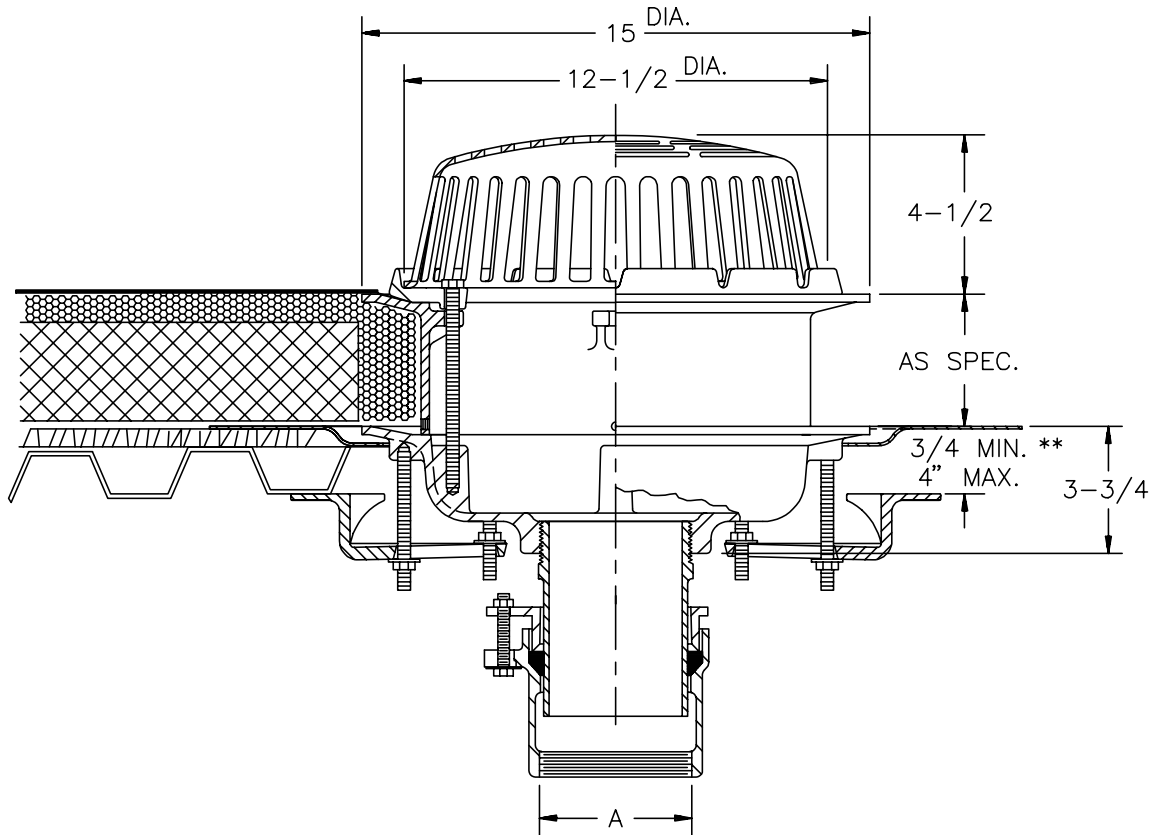

**Z-100-107 15" DIAMETER ROOF DRAIN
WITH STATIC EXTENSION AND
VERTICAL EXPANSION JOINT**

TAG _____

Dimensions Subject to Manufacturing Tolerances



A- Pipe Size In.	Approx. Wt. Lbs.	Dome Open Area Sq. In.
2-3-4	49	103

ENGINEERING SPECIFICATION: ZURN Z-100-C-E-G-R 15" Diameter roof drain. Galvanized cast iron body, static extension, roof sump receiver, under deck clamp, vertical expansion joint and combination membrane flashing clamp/gravel guard and low silhouette dome.

OPTIONS (Check/specify appropriate options)

OUTLET

_____ IP Threaded

PIPE SIZE

(Specify size)

_____ 2" thru 4"

SUFFIXES

- _____ -AC Angular Underdeck Clamp
- _____ -AW 3/4" to 4" Adjustable Water Level Regulator (Previously Z-103-1)
- _____ -BS Bronze Mesh Screen Over Dome
- _____ -DX Dex-o-Tex Flange
- _____ -EA Adjustable Extension Assembly 1-3/4" thru 3-1/2"
- _____ -S Secondary Clamp Collar
- _____ -SS Stainless Mesh Screen Over Dome
- _____ -VP Vandal Proof Secured Top
- _____ -W2 2" Internal Water Dam (Previously Z-103)
- _____ -W3 3" Internal Water Dam " "
- _____ -W4 4" Internal Water Dam " "
- _____ -84 Stainless Steel Perforated Gravel Guard
- _____ -85 Stainless Steel Perforated Extension
- _____ -89 2" High External Water Dam

REV. DATE: 1/3/92 C.N. NO. 67933

DWG. NO. P-13660 PRODUCT NO. Z-100-107

*REGULARLY FURNISHED UNLESS OTHERWISE SPECIFIED

ZURN INDUSTRIES, INC. ♦ SPECIFICATION DRAINAGE OPERATION ♦ 1801 Pittsburgh Ave. ♦ Erie, PA 16514

Phone: 814/455-0921 ♦ Fax: 814/454-7929 ♦ World Wide Web: www.zurn.com

In Canada: ZURN INDUSTRIES LIMITED ♦ 3544 Nashua Drive ♦ Mississauga, Ontario L4V1L2 ♦ Phone: 905/405-8272 Fax: 905/405-1292