



Z1726-83 STAINLESS STEEL ADJUSTABLE FLOOR DRAIN

SPECIFICATION SHEET

TAG _____

Dimensional Data (inches and [mm]) are Subject to Manufacturing Tolerances and Change Without Notice

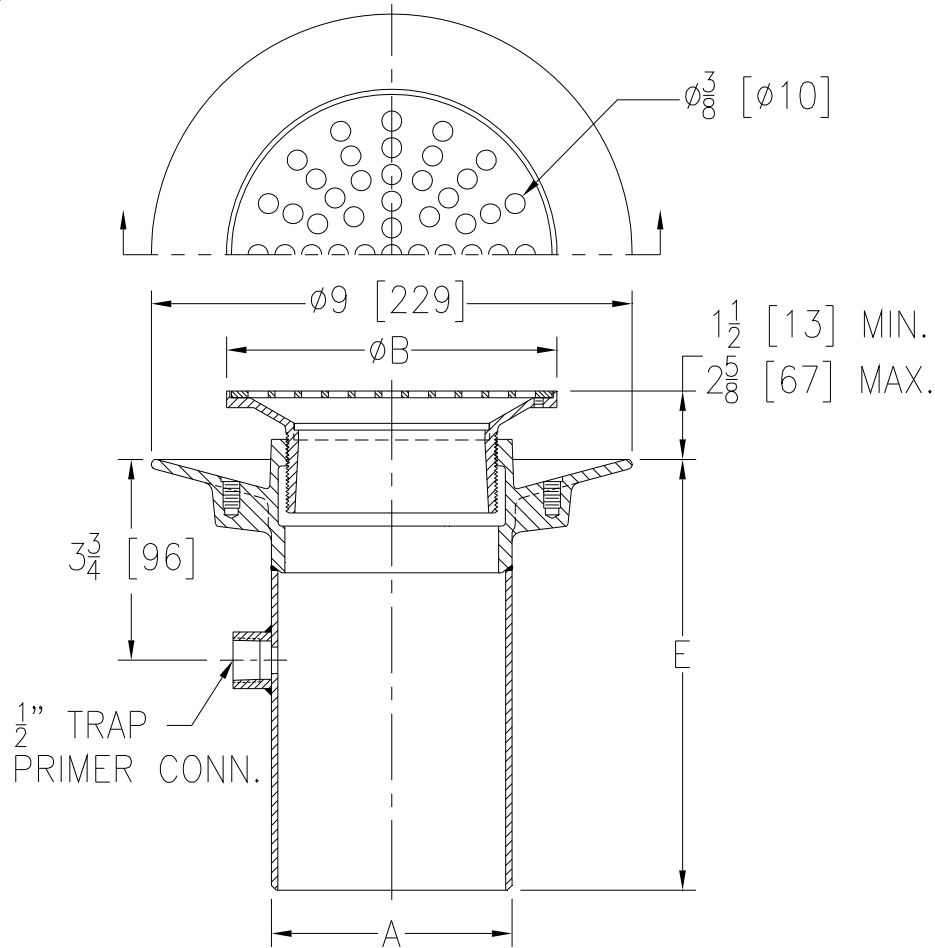

Dimension in Inches		Approx. Wt. Lbs. [kg]	Strainer Open Area Sq. In. [cm ²]
A Pipe Size	B Strainer Dia.		
2,3,4 [51,76,102]	6 [152]	13 [6]	11 [71]

ENGINEERING SPECIFICATION: ZURN Z1726-83
All Type 316 stainless steel adjustable floor drain with anchor flange (clamp collar with seepage holes, when specified), and 6 [152] diameter vertically adjustable top.

OPTIONS (Check/specify appropriate options)

PIPE SIZE
2 thru 4 [51 thru 102]

(Specify size/type) **OUTLET**
____ BW Butt-weld
(Schedule 10 Pipe)

'E' BODY HT. DIM.
8 1/16 [205]

PREFIXES

____ ZM Type 316 (CF8M) Stainless Steel Body*

SUFFIXES

- ____ -K Seepage Holes Only
- ____ -KC Clamp Collar with Seepage Holes
- ____ -SG Solid Gasketed Cover
- ____ -VP Vandal-Proof Secured Top

REV.	DATE: 04/17/09	C.N. NO. 99913
DWG. NO. P-15697	PRODUCT NO. Z1726-83	

*REGULARLY FURNISHED UNLESS OTHERWISE SPECIFIED