



Z-532-79

12 [305] DIAMETER WIDE FLANGE FLOOR DRAIN

SPECIFICATION SHEET

TAG _____

Dimensional Data (inches and [mm]) are Subject to Manufacturing Tolerances and Change Without Notice

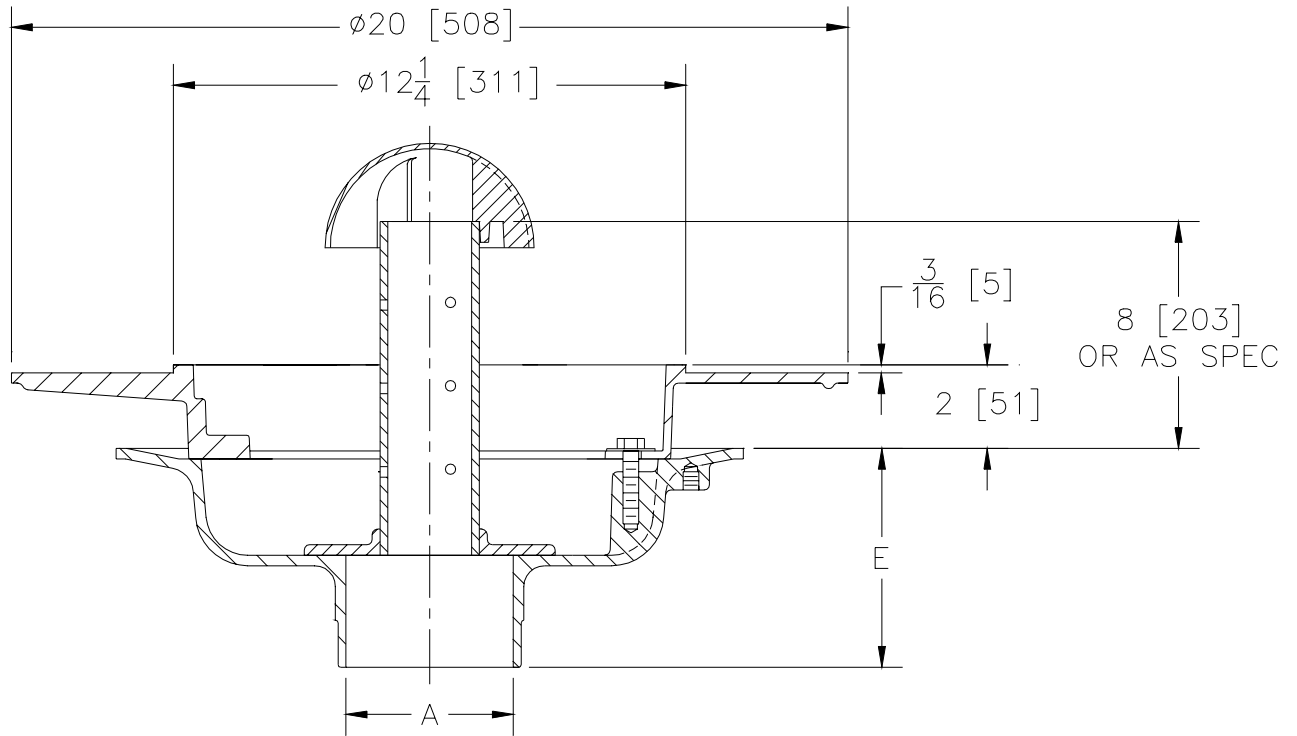

A- Pipe Size In.	Approx. Wt. Lbs. [kg]	Grate Open Area Sq. In. [cm ²]
3 [75]	54 [24]	30 [194]

ENGINEERING SPECIFICATION: ZURN Z-532-79 12 [305] Diameter wide flange floor drain, Dura-Coated cast iron body with bottom outlet, seepage pan and combination membrane flashing clamp and latex troweling flange, with 8 [203] high perforated overflow standpipe with dome.

OPTIONS (Check/specify appropriate options)

PIPE SIZE (Specify size/type) **OUTLET** **'E' BODY HT. DIM.**
 3 [75] _____ NH No-Hub 5 1/4 [133]

PREFIXES

_____ Z- D.C.C.I. Body With Standpipe And Dome*

SUFFIXES

- _____ -C Underdeck Clamp
- _____ -G Galvanized Cast Iron
- _____ -SD Longer Standpipe (Specify Height Required)
(For Each Additional 1 [25] Over 8 [203])
- _____ -SS Stainless Mesh Screen Over Standpipe

*REGULARLY FURNISHED UNLESS OTHERWISE SPECIFIED

REV.	DATE: 4/20/01	C.N. NO. 87618	
DWG. NO. P-14825	PRODUCT NO. Z-532-79		