



# Z1022-XL-DU2

## LOW-LEAD SANI-GARD AUTOMATIC TRAP PRIMER AND 2-OUTLET DISTRIBUTION UNIT

SPECIFICATION SHEET

TAG \_\_\_\_\_

Dimensional Data (inches and [ mm ]) are Subject to Manufacturing Tolerances and Change Without Notice

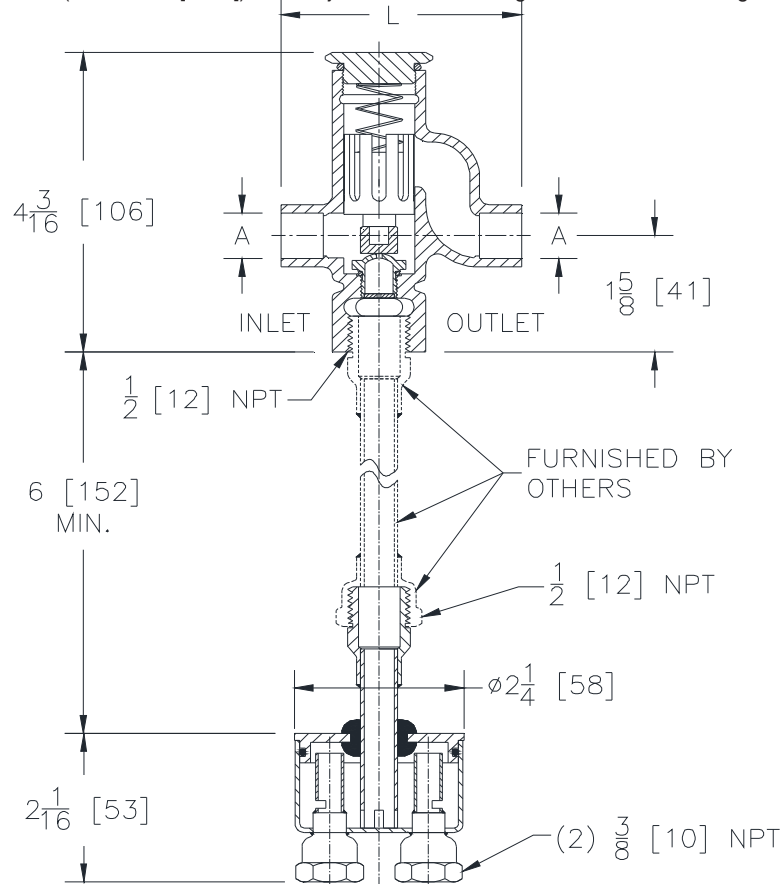

Dimensions In Inches [mm]		Approx. Wt. Lbs. [kg]
A Pipe Size/Connection	L	
1/2 [13] Solder Female	3-7/32 [82]	1.75 [.8]
1/2 [13] IP Female	3-7/32 [82]	1.75 [.8]
1/2 [13] Solder Female Union	5-21/32 [144]	2.25 [1]
1/2 [13] IP Female Union	5-11/32 [136]	2.25 [1]

**ENGINEERING SPECIFICATION: ZURN Z1022-XL-DU2**  
Low-Lead Sani-Gard Automatic Trap Primer, all bronze body with integral vacuum breaker, non-liming internal operating piston, stainless steel spring, removable bronze seat with metering orifice, and sealed bronze cover. Distribution Unit furnished with all brass body, inlet adapter, internal slotted water metering tubes, overflow ports, removable, gasketed transparent cover, complete with (2) 3/8" [10mm] NPT outlet connections.

**Note: This product complies with the lead content requirements as outlined in the Federal Reduction of Lead In Drinking Water Act.**

**PIPE SIZE / CONNECTIONS** (Specify size/type)

- \_\_\_ 1/2 [13] Solder Female\*
- \_\_\_ 1/2 [13] IP Female
- \_\_\_ 1/2 [13] Solder Female Union
- \_\_\_ 1/2 [13] IP Female Union

**PREFIXES**

- \_\_\_ Z All Plain Bronze Trap Primer Body and All Polished Distribution Unit Body\*

**SUFFIXES**

- \_\_\_ -CP Chrome Plated Finish (Trap Primer Only)
- \_\_\_ -LT Less Trap Primer (Z1022-XL)

\* Regularly furnished unless otherwise specified.