



# Z103-45-2OF

15 [381] DIAMETER DEEP SUMP 45° DUAL OUTLET  
ROOF DRAIN W/ 2 [51] HIGH OVERFLOW PIPE

SPECIFICATION SHEET

TAG \_\_\_\_\_

Dimensional Data (inches and [ mm ]) are Subject to Manufacturing Tolerances and Change Without Notice

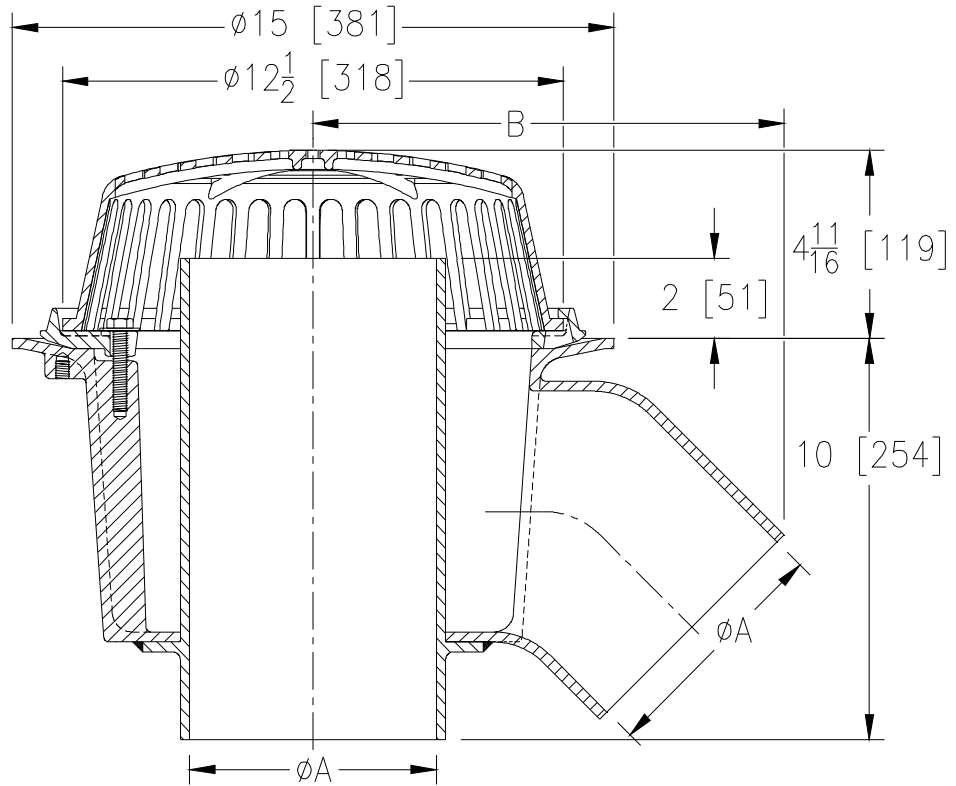

A Pipe Size In. [mm]	B In. [mm]	Approx. Wt. Lbs. [kg]	Dome Open Area Sq. In. [cm <sup>2</sup> ]
3 [76]	9-7/16 [240]	58 [26]	103 [665]
4 [102]	10-1/4 [260]		
6 [152]	10-15/16 [278]		

**ENGINEERING SPECIFICATION: ZURN Z103-45-2OF**  
15" [381mm] Diameter dual outlet roof drain with 45° primary outlet connection. Dura-Coated cast iron deep sump body with combination membrane flashing clamp/gravel guard, 2 [51] high overflow pipe (3", 4", 6" [76mm, 102mm, 152mm]) and low silhouette cast iron dome.

**OPTIONS** (Check/specify appropriate options)

**PIPE SIZE** (Specify size) **OUTLET**  
3, 4, 6 [76, 102, 152] \_\_\_\_\_ NH No-Hub

**PREFIXES**  
\_\_\_\_ Z D.C.C.I. Body w/ Cast Iron Dome\*

- SUFFIXES**
- \_\_\_\_ -AR Acid Resistant Epoxy Coated Finish
  - \_\_\_\_ -C Underdeck Clamp
  - \_\_\_\_ -DP Top-Set® Deck Plate (Replaces both the -C & -R)
  - \_\_\_\_ -G Galvanized Cast Iron
  - \_\_\_\_ -SS Stainless Mesh Screen over Dome
  - \_\_\_\_ -VP Vandal-Proof Secured Top
  - \_\_\_\_ -84 Stainless Steel perforated Gravel Guard

\* Regularly furnished unless otherwise specified.