



Z348-77 DOME TYPE PLANTING AREA DRAIN

SPECIFICATION SHEET

TAG _____

Dimensional Data (inches and [mm]) are Subject to Manufacturing Tolerances and Change Without Notice

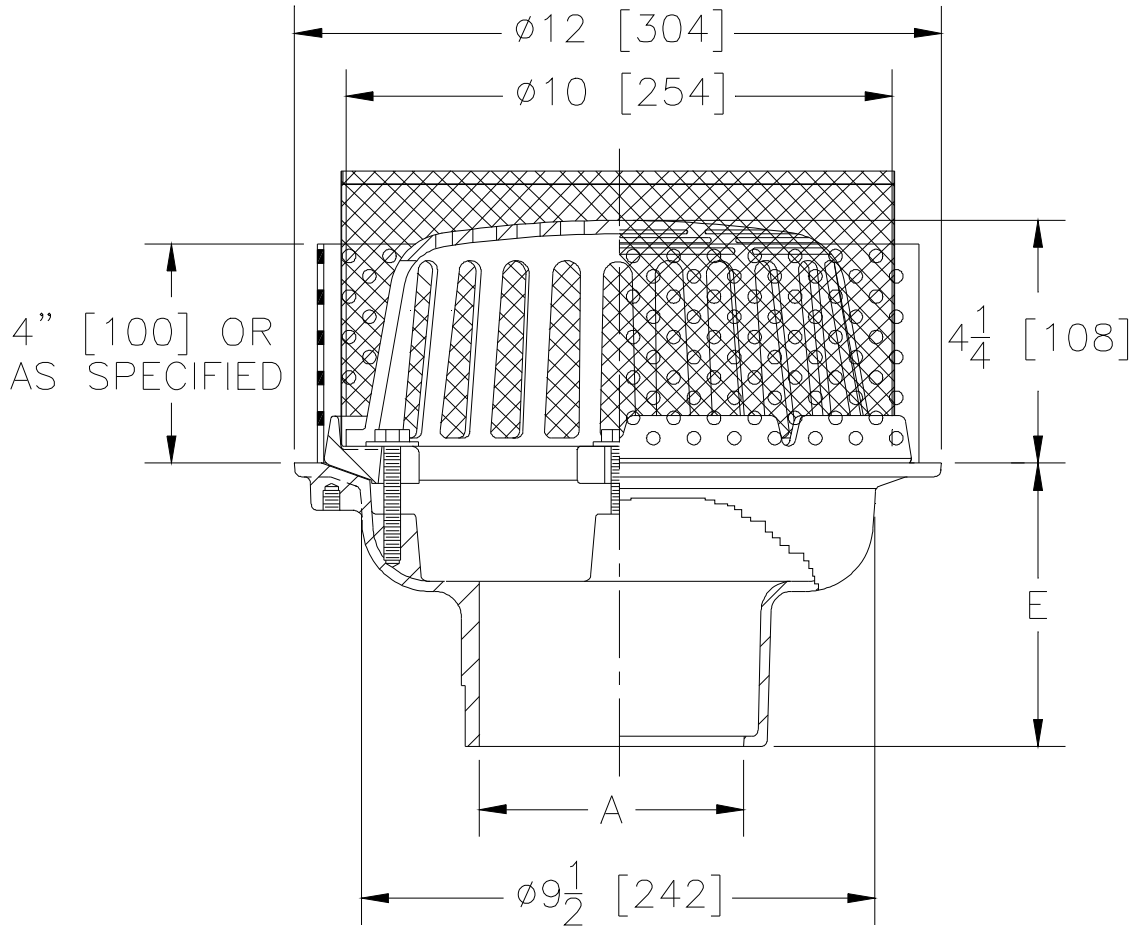

A-Pipe Size Inches	Approx. Wt. Lbs. [kg]	Dome Open Area Sq. In. [cm ²]
2-3-4-6 [51-76-102-152]	23 [10]	78 [503]

ENGINEERING SPECIFICATION: ZURN Z348-77 Dome type planting area drain, Dura-Coated cast iron body with bottom outlet complete with combination membrane flashing clamp/gravel guard, low silhouette dome and stainless steel mesh screen over dome and stainless steel perforated gravel guard.

OPTIONS (Check/specify appropriate options)

PIPE SIZE

- 2-3-4-6 [51-76-102-152]
- 2-3-4-6 [51-76-102-152]
- 2-3-4-6 [51-76-102-152]
- 2-3-4-6 [51-76-102-152]
- 2-3-4 [51-76-102]

(Specify size/type) **OUTLET**

- ___ IC Inside Caulk
- ___ IG Inside Gasket
- ___ IP Threaded
- ___ NH No-Hub
- ___ NL Neo-Loc

'E' BODY HT. DIM.

- 5-1/4 [133]
- 5-1/4 [133]
- 3-3/4 [95]
- 5-1/4 [133]
- 4-5/8 [117]

PREFIXES

- ___ Z D.C.C.I Body, Clamping Collar and Dome*
- ___ ZB D.C.C.I Body, Clamping Collar and Bronze Dome

SUFFIXES

- ___ -G Galvanized Cast Iron
- ___ -SA Stabilizer Assembly (See Z1036)
- ___ -TC Neo-Loc Test Cap Gasket
(2 [51]-4 [102] NL Bottom Outlet Only)

*REGULARLY FURNISHED UNLESS OTHERWISE SPECIFIED

REV. A	DATE: 08/19/11	C.N. NO. 121971
DWG. NO. P-13966		PRODUCT NO. Z348-77

ZURN INDUSTRIES, LLC. ♦ SPECIFICATION DRAINAGE OPERATION ♦ 1801 Pittsburgh Ave. ♦ Erie, PA 16514

Phone: 814/455-0921 ♦ Fax: 814/454-7929 ♦ World Wide Web: www.zurn.com

In Canada: ZURN INDUSTRIES LIMITED ♦ 3544 Nashua Drive ♦ Mississauga, Ontario L4V1L2 ♦ Phone: 905/405-8272 Fax: 905/405-1292