



# Z1188-162

SPECIFICATION SHEET

## SIZE 250 LARGE CAPACITY OIL INTERCEPTOR WITH INTEGRAL EXTENSION AND HEAVY-DUTY COVER

TAG \_\_\_\_\_

Dimensional Data (inches and [ mm ]) are Subject to Manufacturing Tolerances and Change Without Notice

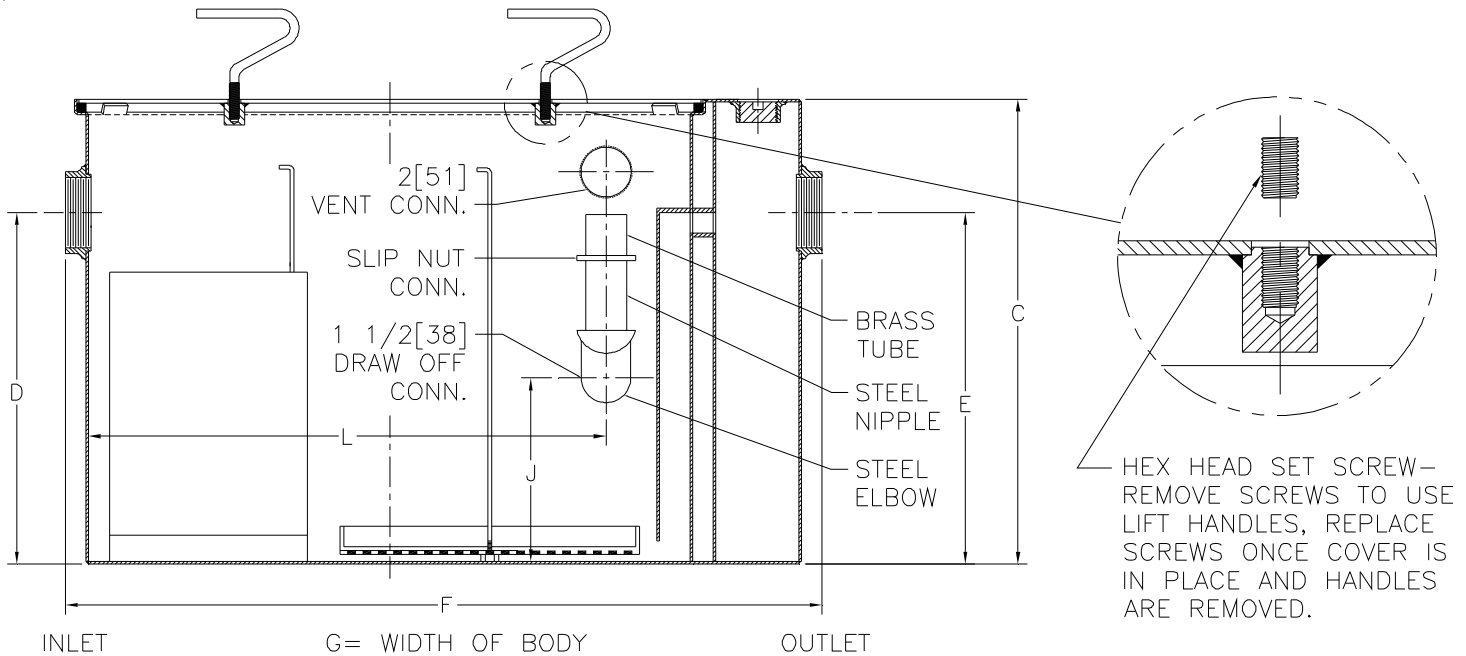

Extension Designation -E	Flow Rate G.P.M. [L/min.]	Inlet/Outlet Size	Water Capacity Gal. [L]	No. of Covers	C	D/E	F	G	J	L
E 35 1/4	250 [946]	6 [152]	460 [1741]	2	76 1/4 [1937]	36 [914]	71 [1803]	51 3/8 [1305]	23 3/8 [594]	56 5/8 [1438]

### ENGINEERING SPECIFICATION: ZURN Z1188-162

Large capacity Acid Resistant Coated interior and exterior fabricated steel oil interceptor with integral extension, bronze cleanout plug and visible double wall trap seal, removable combination pressure equalizing/flow diffusing baffle and sediment bucket, horizontal baffle, adjustable oil drawoff and vent connections either side. Complete with secured, gasketed, non-skid heavy-duty traffic cover rated at 10,000 lbs. [4536 kg.] maximum safe live load with removable lift handles and flow control fitting. Regularly furnished with inlet and outlet in high position.

### OPTIONS (Check/specify appropriate options)

#### PREFIXES

\_\_\_Z Acid Resistant Coated Fabricated Steel\*

#### SUFFIXES

\_\_\_-K Anchor flange 1 3/4 [44] down from top and 2 [51] wide.  
\_\_\_-KC Anchor flange 1 3/4 [44] down from top and 2 [51] wide with clamp collar.

REV. DATE: 03/17/10 C.N. NO. 110851

DWG. NO. P-15861 PRODUCT NO. Z1188-162

\*REGULARLY FURNISHED UNLESS OTHERWISE SPECIFIED

ZURN INDUSTRIES, LLC ♦ SPECIFICATION DRAINAGE OPERATION ♦ 1801 Pittsburgh Ave. ♦ Erie, PA 16514

Phone: 814/455-0921 ♦ Fax: 814/454-7929 ♦ World Wide Web: www.zurn.com

In Canada: ZURN INDUSTRIES LIMITED ♦ 3544 Nashua Drive ♦ Mississauga, Ontario L4V1L2 ♦ Phone: 905/405-8272 Fax: 905/405-1292