



Z568-76

16 [406] SQUARE TOP DRAIN W/ TOP GRATE AND SEDIMENT BUCKET WITH S.S. MESH LINER

SPECIFICATION SHEET

TAG _____

Dimensional Data (inches and [mm]) are Subject to Manufacturing Tolerances and Change Without Notice

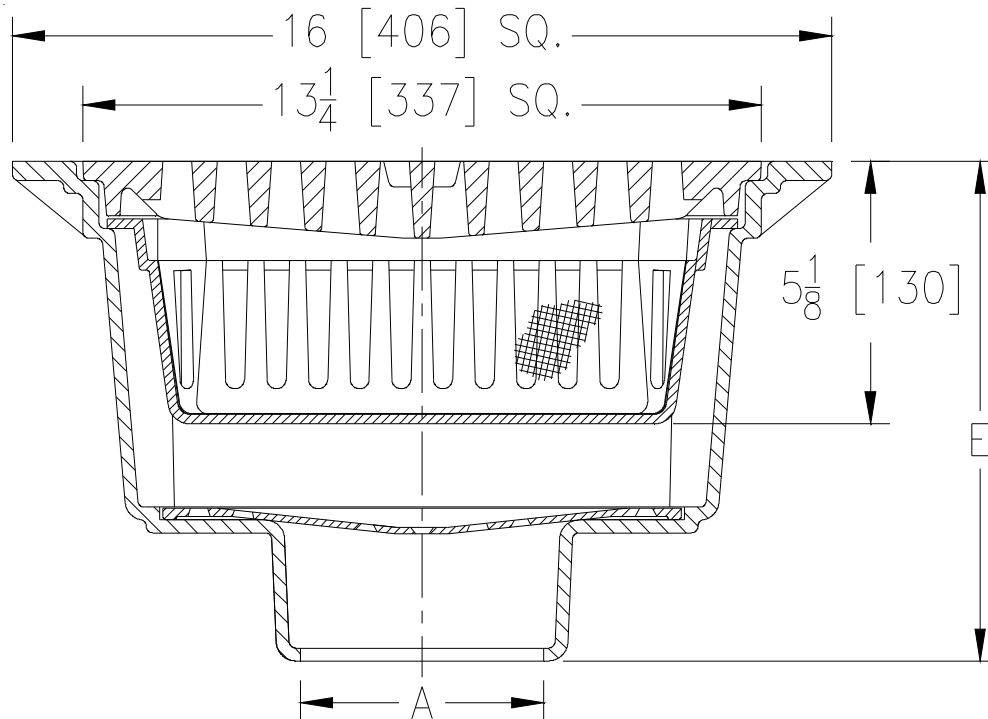

A Pipe Size	Approx. Wt. Lbs. [kg]	Grate Open Area Sq. In.[cm ²]
3-4-6 [76-102-152]	56 [25]	54 [348]

ENGINEERING SPECIFICATION: ZURN Z568-76

16 [406] Square top drain, acid resisting epoxy coated cast iron body with bottom outlet, loose-set cast iron secondary strainer, sediment bucket with stainless steel mesh liner and top grate.

OPTIONS (Check/specify appropriate options)

PIPE SIZE

- 3, 4, 6 [76, 102, 152]
- 3, 4, 6 [76, 102, 152]
- 3 [76]
- 4, 6 [102, 152]
- 3, 4 [76, 102]

(Specify size/type) **OUTLET**

- ___ IC Inside Caulk
- ___ IG Inside Caulk w/Sealtrol Gskt.
- ___ IP Threaded
- ___ IP Threaded
- ___ NL Neo-Loc

'E' BODY HT. DIM.

- 9 3/4 [248]
- 9 3/4 [248]
- 7 7/8 [200]
- 8 1/8 [206]
- 9 [229]

PREFIXES

- ___ Z D.C.C.I. Body and Top*
- ___ ZB D.C.C.I. Body with Polished Bronze Top (Add 3/16 [5] to 'E' Dim.)
- ___ ZN D.C.C.I. Body with Polished Nickel Bronze Top (Add 3/16 [5] to 'E' Dim.)

SUFFIXES

- ___ -G Galvanized Cast Iron
- ___ -K Flange with Seepage Holes
- ___ -KC Flange with Seepage Holes with Clamp Collar
- ___ -TC Neo-Loc Test Cap Gasket (3 - 4 [76 - 102] NL Bottom Outlet Only)

REV.	DATE: 4/6/10	C.N. NO. 110942
DWG. NO. P-15883 PRODUCT NO. Z568-76		

*REGULARLY FURNISHED UNLESS OTHERWISE SPECIFIED